



SERVICE BULLETIN

Classification: RA04-001b	Reference: NTB04-065b	Date: November 9, 2005
------------------------------	--------------------------	---------------------------

2003 – 2005 350Z; CLICKING NOISE FROM REAR AXLES

This bulletin has been amended. The Service Procedure has been revised. No other content has been changed. Discard all previous versions of this bulletin.

APPLIED VEHICLE: 2003 – 2005 350Z (Z33) Coupe and Roadster

IF YOU CONFIRM:

A “clicking” noise is coming from the left and/or right rear axle (driveshaft) when accelerating from a stop,

ACTION:

1. Determine if the noise is coming from one side or both sides.
 - If the noise is coming from **only** one side, perform the Service Procedure on **only** one side.
 - If the noise is coming from both sides, perform the Service Procedure on both sides.
2. Remove the driveshaft, clean the flange surface of the outer joint on the driveshaft and apply a moderate coat of Molykote M77 grease.

NOTE: This is the only approved service procedure to repair this incident.

IMPORTANT: The purpose of "ACTIONS" (above) is to give you a quick idea of the work you will be performing. You **MUST** closely follow the entire Service Procedure (starting on page 3) as it contains information that is essential to successfully completing this repair.

Nissan Bulletins are intended for use by qualified technicians, not 'do-it-yourselfers'. Qualified technicians are properly trained individuals who have the equipment, tools, safety instruction, and know-how to do a job properly and safely. NOTE: If you believe that a described condition may apply to a particular vehicle, DO NOT assume that it does. See your Nissan dealer to determine if this applies to your vehicle.

PARTS INFORMATION

DESCRIPTION	PART NUMBER	QUANTITY
Molykote M77 Grease	44003-7S000	As Needed *
Bolts (Driveshaft Side Flange)	39606-22P00	6 per side
Nuts (Driveshaft Side Flange)	39607-03P00	6 per side
Washers (Driveshaft Side Flange)	08915-1401A	6 per side
Cotter Pin	40073-0L700	1 per side

* Order from your local Parts Distribution Center (PDC).

NOTE: P/N 44003-7S000 is considered a shop supply – do NOT include it on your warranty claim.

CLAIMS INFORMATION

If only ONE Driveshaft Flange is lubricated with Molykote Grease, submit a Primary Failed Part (PP) line claim using the following claims coding:

DESCRIPTION	PFP	OP CODE	SYM	DIA	FRT
Repair Rear Driveshaft Noise - One Side	39211-73L00	NX03AA	ZL	32	0.7 hrs

OR

If BOTH Driveshaft Flanges are lubricated with Molykote Grease, submit a Primary Failed Part (PP) line claim using the following claims coding:

DESCRIPTION	PFP	OP CODE	SYM	DIA	FRT
Repair Rear Driveshaft Noise - Both Sides	39211-73L00	NX04AA	ZL	32	1.1 hrs

SERVICE PROCEDURE

1. Determine if the noise is coming from one side or both sides.
 - If the noise is coming from **only** one side, perform procedure on **only** one side.
 - If the noise is coming from both sides, perform procedure on both sides.
2. Remove the rear axle (driveshaft).
 - Refer to section RAX in the Service Manual for the driveshaft removal information.
 - **IMPORTANT:** Make sure to mark the driveshaft and hub as shown in Figure 1 before removing the driveshaft.

Put a mark on the end of the driveshaft and a matching mark on the hub as shown in Figure 1.

NOTE: These marks will be used when reinstalling the driveshaft.

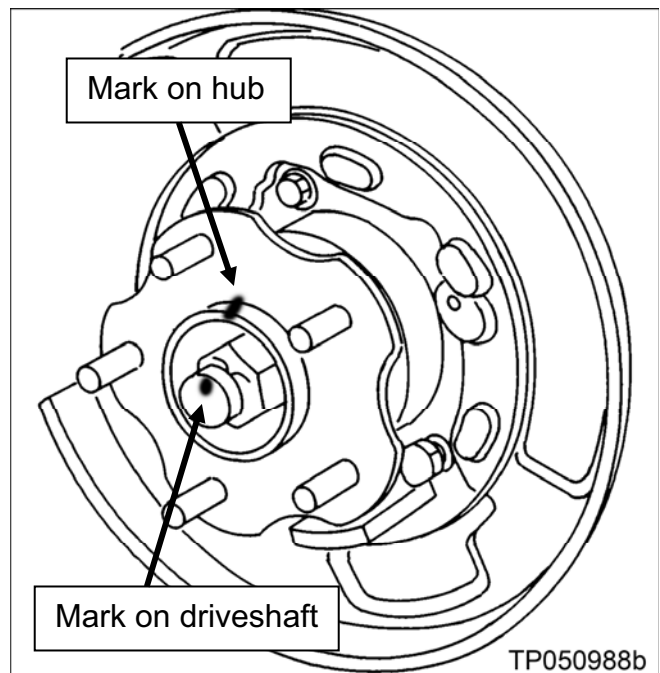

Figure 1