

# DTC P2135 TP SENSOR

PF:16119

ABS009NX

## DTC P2135 TP SENSOR

### Component Description

Electric throttle control actuator consists of throttle control motor, throttle position sensor, etc. The throttle position sensor responds to the throttle valve movement.

The throttle position sensor has two sensors. These sensors are a kind of potentiometers which transform the throttle valve position into output voltage, and emit the voltage signal to the ECM. In addition, these sensors detect the opening and closing speed of the throttle valve and feed the voltage signals to the ECM. The ECM judges the current opening angle of the throttle valve from these signals and the ECM controls the throttle control motor to make the throttle valve opening angle properly in response to driving condition.

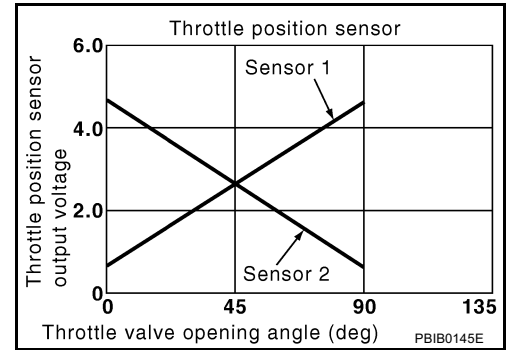

### CONSULT-II Reference Value in Data Monitor Mode

ABS009NY

Specification data are reference values.

MONITOR ITEM	CONDITION		SPECIFICATION
THRTL SEN 1 THRTL SEN 2*	● Ignition switch: ON (Engine stopped)	Accelerator pedal: Fully released	More than 0.36V
	● Shift lever: D (A/T), 1st (M/T)	Accelerator pedal: Fully depressed	Less than 4.75V

\*: Throttle position sensor 2 signal is converted by ECM internally. Thus, it differs from ECM terminal voltage signal.

### On Board Diagnosis Logic

ABS009NZ

This self-diagnosis has the one trip detection logic.

DTC No.	Trouble diagnosis name	DTC detecting condition	Possible cause
P2135 2135	Throttle position sensor circuit range/performance problem	Rationally incorrect voltage is sent to ECM compared with the signals from TP sensor 1 and TP sensor 2.	<ul style="list-style-type: none"> <li>● Harness or connector (The TP sensor 1 and 2 circuit is open or shorted.) (The APP sensor 2 circuit is shorted.)</li> <li>● Electric throttle control actuator (TP sensor 1 and 2)</li> <li>● Accelerator pedal position sensor (APP sensor 2)</li> </ul>

### FAIL-SAFE MODE

When the malfunction is detected, the ECM enters fail-safe mode and the MIL lights up.

Engine operation condition in fail-safe mode

The ECM controls the electric throttle control actuator in regulating the throttle opening in order for the idle position to be within +10 degrees.

The ECM regulates the opening speed of the throttle valve to be slower than the normal condition.

So, the acceleration will be poor.

# DTC P2135 TP SENSOR

ABS00900

## DTC Confirmation Procedure

### NOTE:

If DTC Confirmation Procedure has been previously conducted, always turn ignition switch OFF and wait at least 10 seconds before conducting the next test.

### TESTING CONDITION:

Before performing the following procedure, confirm that battery voltage is more than 10V at idle.

#### WITH CONSULT-II

1. Turn ignition switch ON.
2. Select "DATA MONITOR" mode with CONSULT-II.
3. Start engine and let it idle for 1 second.
4. If DTC is detected, go to [EC-675, "Diagnostic Procedure"](#) .

DATA MONITOR	
MONITOR	NO DTC
ENG SPEED	XXX rpm

SEF058Y

#### WITH GST

Follow the procedure "WITH CONSULT-II" above.

# DTC P2135 TP SENSOR

## Wiring Diagram

ABS00901

### EC-TPS3-01

: DETECTABLE LINE FOR DTC  
 : NON-DETECTABLE LINE FOR DTC

A

EC

C

D

E

F

G

H

I

J

K

L

M

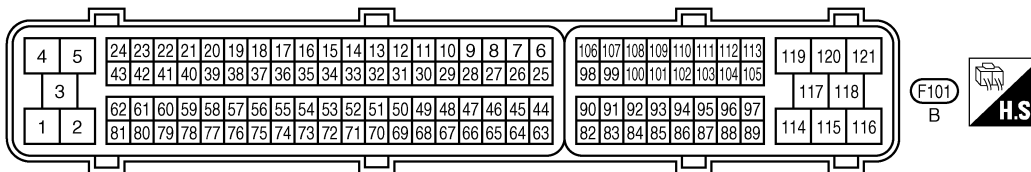
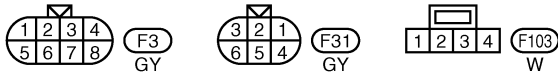
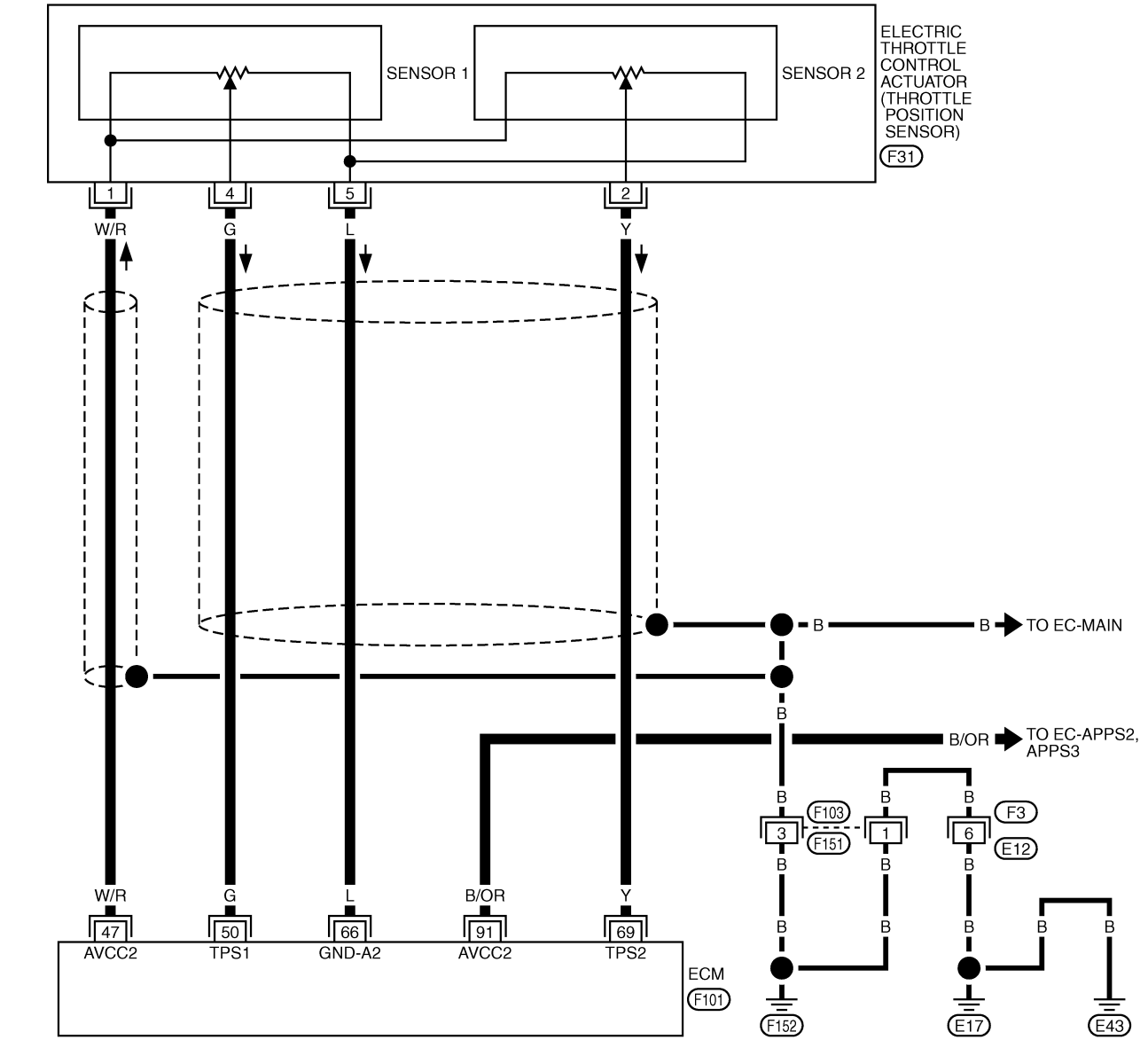

TBWT0785E

## DTC P2135 TP SENSOR

Specification data are reference values and are measured between each terminal and ground.

**CAUTION:**

**Do not use ECM ground terminals when measuring input/output voltage. Doing so may result in damage to the ECM's transistor. Use a ground other than ECM terminals, such as the ground.**

TER-MINAL NO.	WIRE COLOR	ITEM	CONDITION	DATA (DC Voltage)
47	W/R	Sensor power supply (Throttle position sensor)	<b>[Ignition switch: ON]</b>	Approximately 5V
50	G	Throttle position sensor 1	<b>[Ignition switch: ON]</b> <ul style="list-style-type: none"> <li>● Engine stopped</li> <li>● Shift lever: D (A/T) or 1st (M/T)</li> <li>● Accelerator pedal: Fully released</li> </ul>	More than 0.36V
			<b>[Ignition switch: ON]</b> <ul style="list-style-type: none"> <li>● Engine stopped</li> <li>● Shift lever: D (A/T) or 1st (M/T)</li> <li>● Accelerator pedal: Fully depressed</li> </ul>	Less than 4.75V
66	L	Sensor ground (Throttle position sensor)	<b>[Engine is running]</b> <ul style="list-style-type: none"> <li>● Warm-up condition</li> <li>● Idle speed</li> </ul>	Approximately 0V
69	Y	Throttle position sensor 2	<b>[Ignition switch: ON]</b> <ul style="list-style-type: none"> <li>● Engine stopped</li> <li>● Shift lever: D (A/T) or 1st (M/T)</li> <li>● Accelerator pedal: Fully released</li> </ul>	Less than 4.75V
			<b>[Ignition switch: ON]</b> <ul style="list-style-type: none"> <li>● Engine stopped</li> <li>● Shift lever: D (A/T) or 1st (M/T)</li> <li>● Accelerator pedal: Fully depressed</li> </ul>	More than 0.36V
91	B/OR	Sensor power supply (Accelerator pedal position sensor 2)	<b>[Ignition switch: ON]</b>	Approximately 5V

# DTC P2135 TP SENSOR

ABS00902

## Diagnostic Procedure

### 1. CHECK GROUND CONNECTIONS

1. Turn ignition switch OFF.
2. Loosen and retighten three ground screws on the body. Refer to [EC-175. "Ground Inspection"](#).

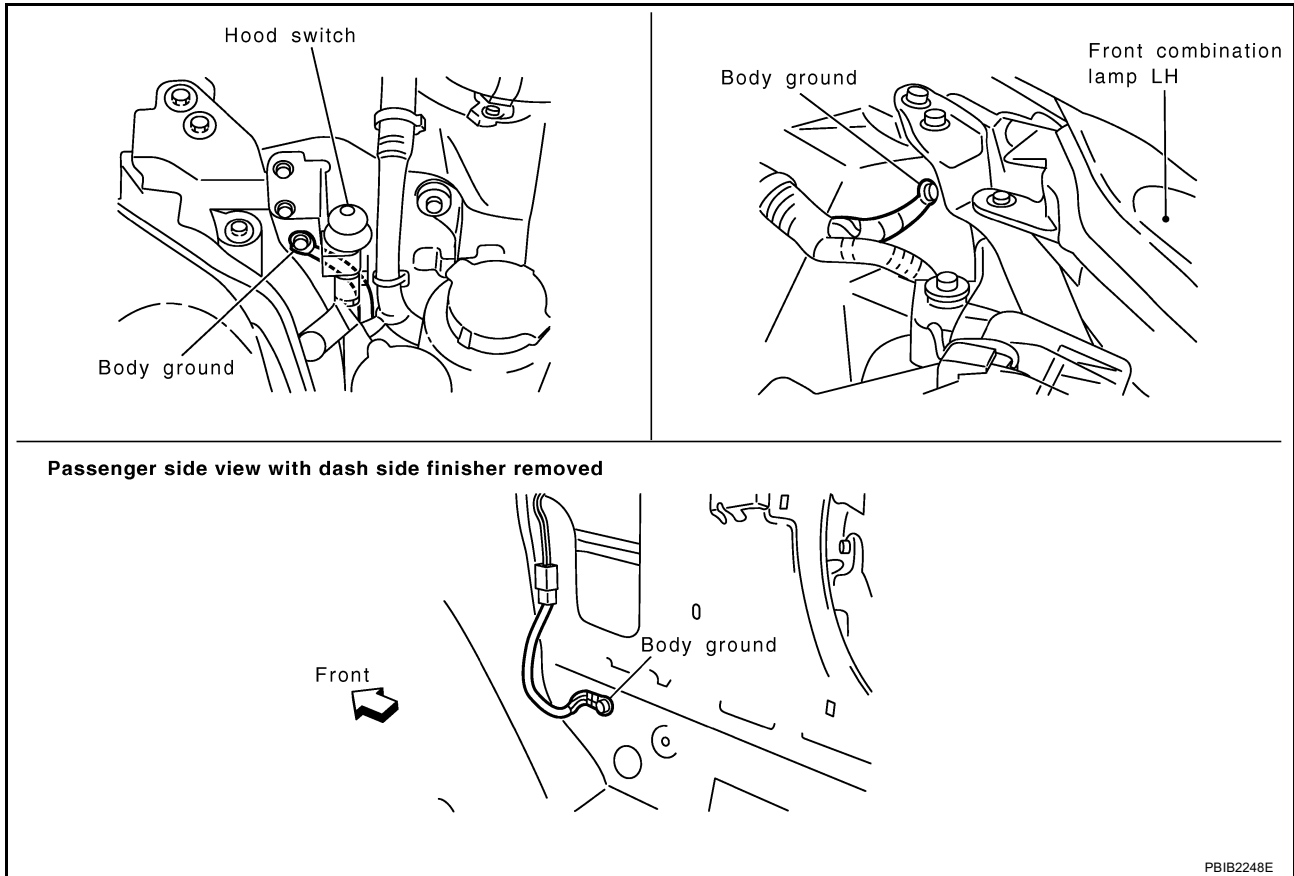

#### OK or NG

- OK >> GO TO 2.
- NG >> Repair or replace ground connections.

A  
EC  
C  
D  
E  
F  
G  
H  
I  
J  
K  
L  
M

# DTC P2135 TP SENSOR

## 2. CHECK THROTTLE POSITION SENSOR POWER SUPPLY CIRCUIT-I

1. Disconnect electric throttle control actuator harness connector.
2. Turn ignition switch ON.

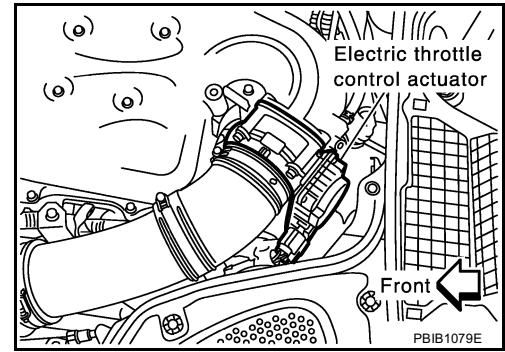

3. Check voltage between electric throttle control actuator terminal 1 and ground with CONSULT-II or tester.

**Voltage: Approximately 5V**

OK or NG

- OK >> GO TO 7.
- NG >> GO TO 3.

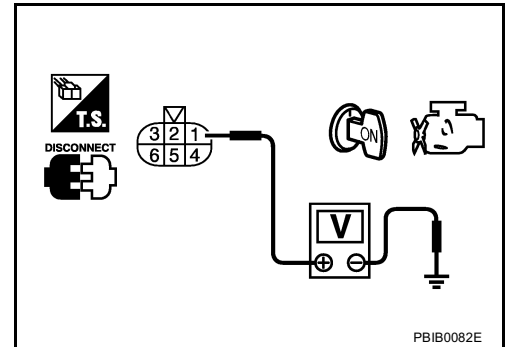

## 3. CHECK THROTTLE POSITION SENSOR POWER SUPPLY CIRCUIT-II

1. Turn ignition switch OFF.
2. Disconnect ECM harness connector.
3. Check harness continuity between electric throttle control actuator terminal 1 and ECM terminal 47. Refer to Wiring Diagram.

**Continuity should exist.**

OK or NG

- OK >> GO TO 4.
- NG >> Repair open circuit.

## 4. CHECK THROTTLE POSITION SENSOR POWER SUPPLY CIRCUIT-III

Check harness for short to power and short to ground, between the following terminals.

ECM terminal	Sensor terminal	Reference Wiring Diagram
47	Electric throttle control actuator terminal 1	<a href="#">EC-673</a>
91	APP sensor terminal 4	<a href="#">EC-665</a>

OK or NG

- OK >> GO TO 5.
- NG >> Repair short to ground or short to power in harness or connectors.

## 5. CHECK APP SENSOR

Refer to [EC-670](#). "Component Inspection".

OK or NG

- OK >> GO TO 11.
- NG >> GO TO 6.

# DTC P2135 TP SENSOR

---

## 6. REPLACE ACCELERATOR PEDAL ASSEMBLY

---

1. Replace accelerator pedal assembly.
2. Perform [EC-91, "Accelerator Pedal Released Position Learning"](#) .
3. Perform [EC-91, "Throttle Valve Closed Position Learning"](#) .
4. Perform [EC-92, "Idle Air Volume Learning"](#) .

**>> INSPECTION END**

---

## 7. CHECK THROTTLE POSITION SENSOR GROUND CIRCUIT FOR OPEN AND SHORT

---

1. Turn ignition switch OFF.
2. Disconnect ECM harness connector.
3. Check harness continuity between electric throttle control actuator terminal 5 and ECM terminal 66. Refer to Wiring Diagram.

**Continuity should exist.**

4. Also check harness for short to ground and short to power.

OK or NG

OK >> GO TO 8.

NG >> Repair open circuit or short to ground or short to power in harness or connectors.

---

## 8. CHECK THROTTLE POSITION SENSOR INPUT SIGNAL CIRCUIT FOR OPEN AND SHORT

---

1. Check harness continuity between the following;  
ECM terminal 50 and electric throttle control actuator terminal 4,  
ECM terminal 69 and electric throttle control actuator terminal 2.  
Refer to Wiring Diagram.

**Continuity should exist.**

2. Also check harness for short to ground and short to power.

OK or NG

OK >> GO TO 9.

NG >> Repair open circuit or short to ground or short to power in harness or connectors.

---

## 9. CHECK THROTTLE POSITION SENSOR

---

Refer to [EC-678, "Component Inspection"](#) .

OK or NG

OK >> GO TO 11.

NG >> GO TO 10.

---

## 10. REPLACE ELECTRIC THROTTLE CONTROL ACTUATOR

---

1. Replace the electric throttle control actuator.
2. Perform [EC-91, "Throttle Valve Closed Position Learning"](#) .
3. Perform [EC-92, "Idle Air Volume Learning"](#) .

**>> INSPECTION END**

---

## 11. CHECK INTERMITTENT INCIDENT

---

Refer to [EC-166, "TROUBLE DIAGNOSIS FOR INTERMITTENT INCIDENT"](#) .

**>> INSPECTION END**

# DTC P2135 TP SENSOR

ABS00903

## Component Inspection THROTTLE POSITION SENSOR

1. Reconnect all harness connectors disconnected.
2. Perform [EC-91, "Throttle Valve Closed Position Learning"](#) .
3. Turn ignition switch ON.
4. Set shift lever to D (A/T) or 1st (M/T) position.
5. Check voltage between ECM terminals 50 (TP sensor 1 signal), 69 (TP sensor 2 signal) and ground under the following conditions.

Terminal	Accelerator pedal	Voltage
50 (Throttle position sensor 1)	Fully released	More than 0.36V
	Fully depressed	Less than 4.75V
69 (Throttle position sensor 2)	Fully released	Less than 4.75V
	Fully depressed	More than 0.36V

6. If NG, replace electric throttle control actuator and go to the next step.
7. Perform [EC-91, "Throttle Valve Closed Position Learning"](#) .
8. Perform [EC-92, "Idle Air Volume Learning"](#) .

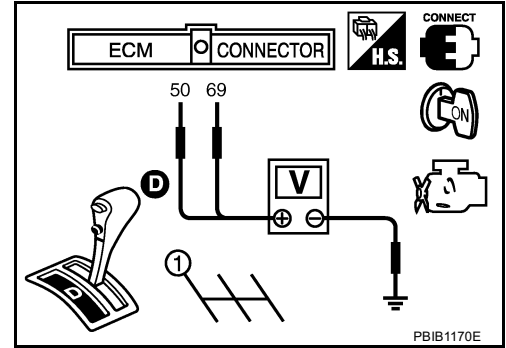

## Removal and Installation ELECTRIC THROTTLE CONTROL ACTUATOR

ABS00904

Refer to [EM-17, "INTAKE MANIFOLD COLLECTOR"](#) .