



10/24/2006

11493

NISSAN 350Z

GROSS LOAD CAPACITY WHEN USED AS A WEIGHT CARRYING HITCH: 1,500 LBS. TRAILER WEIGHT & 150 LBS. TONGUE WEIGHT.
*****DO NOT EXCEED VEHICLE MANUFACTURER'S RECOMMENDED TOWING CAPACITY.*****

Parts List			
ITEM	QTY	PART NUMBER	DESCRIPTION
1	1	1/2"	FISHWIRE TOOL
2	4	HFN 1213	HEX FLANGE NUT
3	4	1/2-13 x 1 1/2	CARRIAGE BOLT
4	4	CM-SP6	.250 x 1.00 x 3.00" SQUARE HOLE SPACER
5	1	D-55001	1 1/4" CURT BALL MOUNT
6	1	F-4 PIN	HITCH PIN
7	1	F-4 CLIP	HITCH PIN CLIP

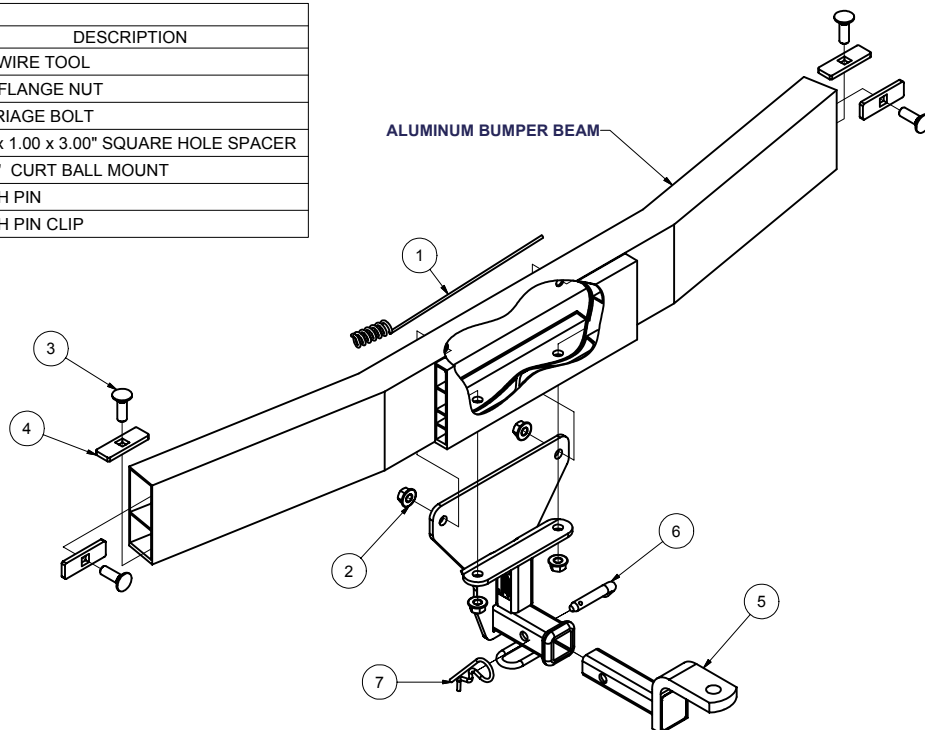

HITCH WEIGHT: 13 LBS.

INSTALL TIME: 90 MINUTES

INSTALL NOTES:

- REMOVE TAIL LIGHTS
- REMOVE BUMPER FASCIA
- REMOVE BUMPER BEAM
- DRILLING REQUIRED

INSTALLATION STEPS

- 1) Remove the (3) 10mm screws holding the tail light lens (located under the (3) plastic covers inside trunk). Carefully remove lights including 2 tabs and disconnect from the wiring harness.
- 2) Remove the 10mm screw located under the lens that holds the bumper onto the vehicle and remove the white plastic clip that holds the bumper to the body (either press the tabs together or turn the clip 90 degrees to remove).
- 3) Remove the (3) screws that hold the mud flaps in place (if equipped) to gain access to the 10mm screw located on the bottom the bumper.
- 4) Remove the Two black fasteners the hold the bumper tabs to the underside of the bumper and gently pull the bumper fascia straight back.
- 5) Disconnect the 3 electrical plugs (2 for reverse lights and 1 license plate light)
- 6) Center the hitch on the bumper beam, using the hitch as a template and mark the two bottom holes
- 7) Remove the aluminum bumper reinforcement by removing the (8) 12mm screws there are 4 located on each side.
- 8) Drill the two holes that you marked earlier first with a pilot bit and enlarge to a 1/2 hole.
- 9) Fishwire the 1/2 carriage bolts and spacers into the drilled hole through the end of the bumper.
- 10) Secure the hitch with hex flange nuts loosely, drill the remaining holes, Fishwire the remaining fasteners into place and install remaining nuts.
- 11) Torque all 1/2" fasteners to 75 lb-ft.
- 12) Replace the aluminum bumper support, taillights, and bumper fascia. Trim bumper fascia approximately 1 3/4 x 2 for proper fit.

PERIODICALLY CHECK THIS RECEIVER HITCH TO INSURE THAT ALL FASTENERS ARE TIGHT AND THAT ALL STRUCTURAL COMPONENTS ARE SOUND.

Curt Manufacturing Inc., warrants this product to be free of defects in material and/or workmanship at the time of retail purchase by the original purchaser. If the product is found to be defective, Curt Manufacturing Inc., may repair or replace the product, at their option, when the product is returned, prepaid, with proof of purchase. Alteration to, misuse of, or improper installation of this product voids the warranty. Curt Manufacturing Inc.'s liability is limited to repair or replacement of products found to be defective, and specifically excludes liability for incidental or consequential loss or damage.

5/25/06