

SOFT TOP

2. CHECK ROOF ACTUATOR CIRCUIT

1. Turn ignition switch OFF.
2. Disconnect soft top control unit connector.
3. Check the following.
 - Continuity between soft top control unit connector B68 terminal 37, 42 and roof actuator (LH) connector B59 terminal 1, 2.

37 (R) - 2 (R) : Continuity should exist.

42 (Y) - 1 (Y) : Continuity should exist.

- Continuity between soft top control unit connector B68 terminal 37, 42 and ground.

37 (R) - Ground : Continuity should not exist.

42 (Y) - Ground : Continuity should not exist.

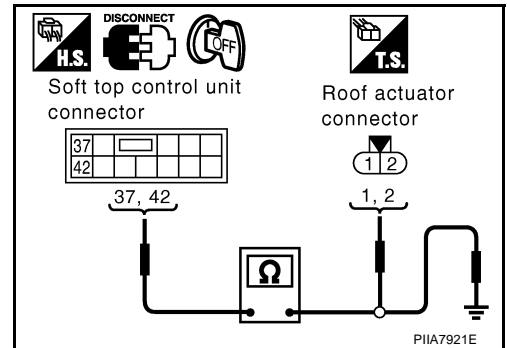

4. Check the following.
 - Continuity between soft top control unit connector B66 terminal 3, 10 and roof actuator (RH) connector B72 terminal 1, 2.

3 (R) - 1 (R) : Continuity should exist.

10 (Y) - 2 (Y) : Continuity should exist.

- Continuity between soft top control unit connector B66 terminal 3, 10 and ground.

3 (R) - Ground : Continuity should not exist.

10 (Y) - Ground : Continuity should not exist.

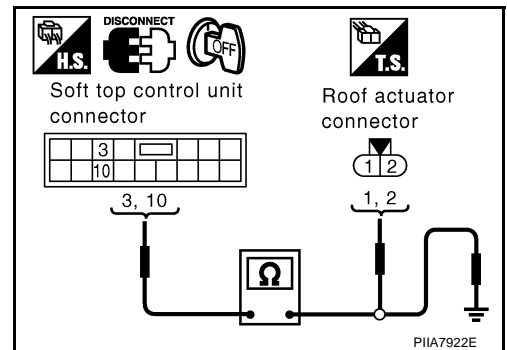

OK or NG

OK >> Replace soft top control unit.

NG >> Repair or replace harness.

Roof Full Close Detection Switch Check

AIS00640

1. CHECK ROOF FULL CLOSE DETECTION SWITCH SIGNAL

1. Start engine.
2. Operate soft top switch CLOSE, check voltage between soft top control unit connector and ground.

Connector	Terminal (Wire color)		Roof condition	Voltage (V) (Approx.)
	(+)	(-)		
B67	20 (W/B)	Ground	CL5 → CL6	0 → 5

OK or NG

OK >> Roof full close detection switch is OK.

NG >> GO TO 2.

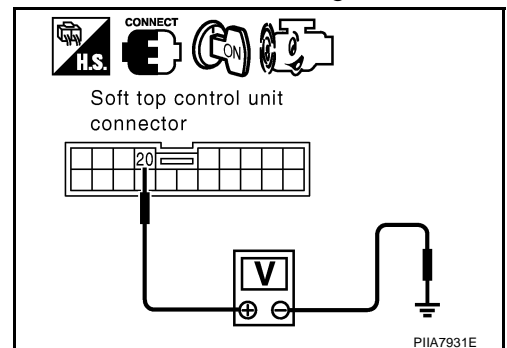

SOFT TOP

2. CHECK ROOF FULL CLOSE DETECTION SWITCH CIRCUIT

1. Turn ignition switch OFF.
2. Disconnect soft top control unit and soft top switch assembly 2 (roof full close detection switch) connector.
3. Check continuity between soft top control unit connector B67 terminal 20 and soft top switch assembly 2 connector B213 terminal 2.

20 (W/B) - 2 (W/G) : Continuity should exist.

4. Check continuity between soft top control unit connector B67 terminal 20 and ground.

20 (W/B) - Ground : Continuity should not exist.

OK or NG

OK >> GO TO 3.

NG >> Repair or replace harness.

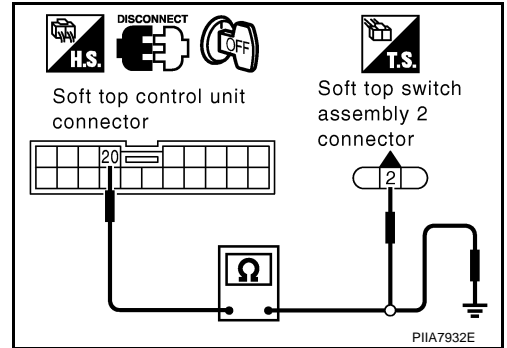

3. CHECK ROOF FULL CLOSE DETECTION SWITCH GROUND CIRCUIT

Check continuity between soft top switch assembly 2 connector B213 terminal 1 and ground.

1 (B) - Ground : Continuity should exist.

OK or NG

OK >> GO TO 4.

NG >> Repair or replace harness.

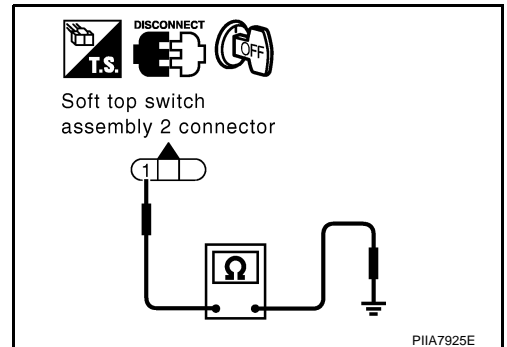

4. CHECK SOFT TOP CONTROL UNIT OUTPUT SIGNAL

1. Connect soft top control unit connector.
2. Start engine.
3. Check voltage between soft top control unit connector B67 terminal 20 and ground.

20 (W/B) - Ground : Approx. 5V

OK or NG

OK >> Replace soft top switch assembly 2.

NG >> Replace soft top control unit.

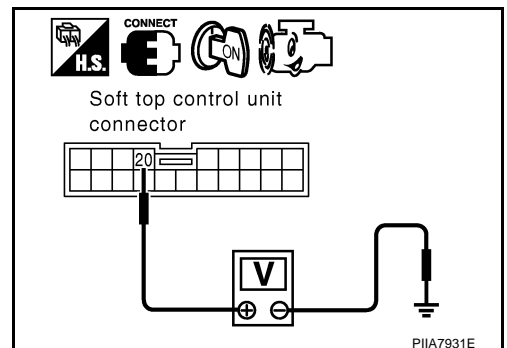

SOFT TOP

5th Bow Actuator Check (Close Operate)

AIS0064P

1. CHECK 5TH BOW ACTUATOR INPUT SIGNAL

1. Start engine.
2. Operate soft top switch CLOSE, check voltage between 5th bow actuator connector and ground.

Connector	Terminal (Wire color)		Roof condition	Voltage (V) (Approx.)
	(+)	(-)		
B233	1 (G/Y)	Ground	CL4 → CL5	0 → Battery voltage → 0

OK or NG

- OK >> Replace 5th bow actuator.
 NG >> GO TO 2.

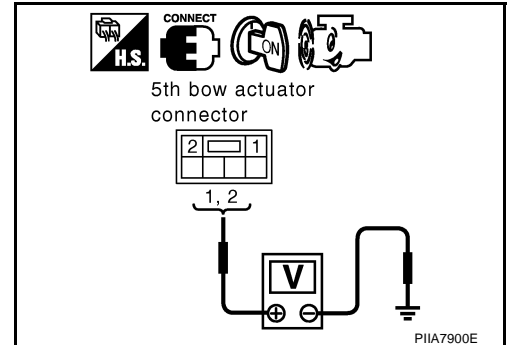

2. CHECK 5TH BOW ACTUATOR CIRCUIT

1. Turn ignition switch OFF.
2. Disconnect soft top control unit and 5th bow actuator connector.
3. Check continuity between soft top control unit connector B68 terminal 44, 45 and 5th bow actuator connector B233 terminal 1, 2.

44 (G/R) - 1 (G/Y) : Continuity should exist.

45 (G/Y) - 2 (G/R) : Continuity should exist.

4. Check continuity between soft top control unit connector B68 terminal 44, 45 and ground.

44 (G/R) - Ground : Continuity should not exist.

45 (G/Y) - Ground : Continuity should not exist.

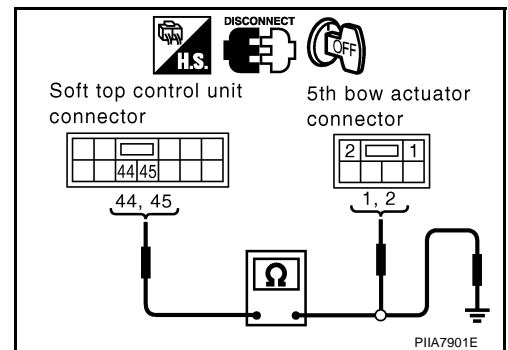

OK or NG

- OK >> Replace soft top control unit.
 NG >> Repair or replace harness.

5th Bow Full Close Detection Switch Check (Close Operate)

AIS0064Q

1. CHECK 5TH BOW FULL CLOSE DETECTION SWITCH SIGNAL

1. Start engine.
2. Operate soft top switch CLOSE, check voltage between soft top control unit connector and ground.

Connector	Terminal (Wire color)		Roof condition	Voltage (V) (Approx.)
	(+)	(-)		
B67	27 (W/G)	Ground	CL5 → CL6	0 → 5 → 0

OK or NG

- OK >> 5th bow full close switch is OK.
 NG >> GO TO 2.

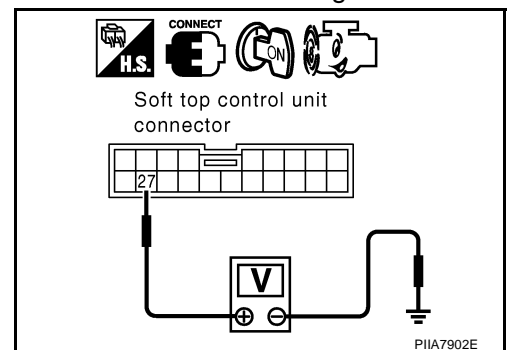

SOFT TOP

2. CHECK 5TH BOW FULL CLOSE DETECTION SWITCH CIRCUIT

1. Turn ignition switch OFF.
2. Disconnect soft top control unit and 5th bow switch assembly (at plate rail RR) connector.
3. Check continuity between soft top control unit connector B67 terminal 27 and 5th bow switch assembly connector B214 terminal 2.

27 (W/G) - 2 (W/G) : Continuity should exist.

4. Check continuity between soft top control unit connector B67 terminal 27 and ground.

27 (W/G) - Ground : Continuity should not exist.

OK or NG

OK >> GO TO 3.

NG >> Repair or replace harness.

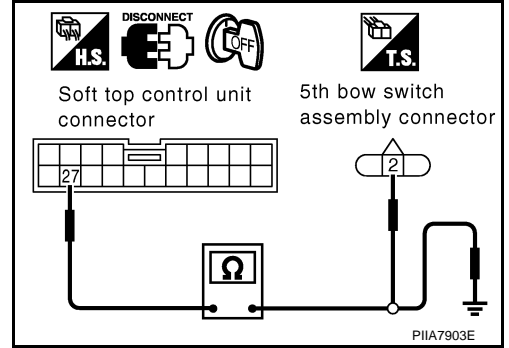

3. CHECK 5TH BOW FULL CLOSE DETECTION SWITCH GROUND CIRCUIT

Check continuity between 5th bow switch assembly connector B214 terminal 3 and ground.

3 (B) - Ground : Continuity should exist.

OK or NG

OK >> GO TO 4.

NG >> Repair or replace harness.

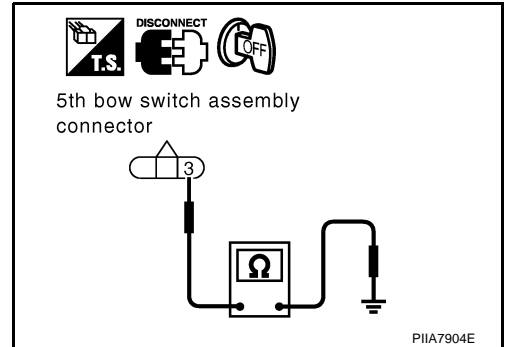

4. CHECK SOFT TOP CONTROL UNIT OUTPUT SIGNAL

1. Connect soft top control unit connector.
2. Start engine.
3. Check voltage between soft top control unit connector B67 terminal 27 and ground.

27 (W/G) - Ground : Approx. 5V

OK or NG

OK >> Replace plate rail RR.

NG >> Replace soft top control unit.

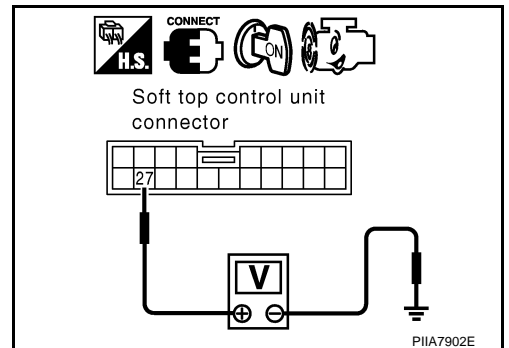

SOFT TOP

AIS0064R

5th Bow Full Open Detection Switch Check (Close Operate)

1. CHECK 5TH BOW FULL OPEN DETECTION SWITCH SIGNAL

1. Start engine.
2. Operate soft top switch CLOSE, check voltage between soft top control unit connector and ground.

Connector	Terminal (Wire color)		Roof condition	Voltage (V) (Approx.)
	(+)	(-)		
B67	26 (LG)	Ground	CL6 → CL7	5 → 0

OK or NG

- OK >> 5th bow full open switch is OK.
 NG >> GO TO 2.

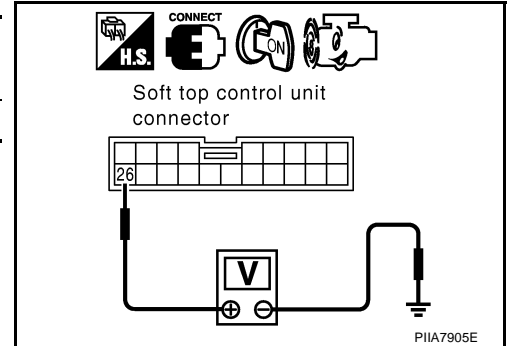

2. CHECK 5TH BOW FULL OPEN DETECTION SWITCH CIRCUIT

1. Turn ignition switch OFF.
2. Disconnect soft top control unit and 5th bow switch assembly connector.
3. Check continuity between soft top control unit connector B67 terminal 26 and 5th bow switch assembly connector B214 terminal 1.

26 (LG) - 1 (LG) : Continuity should exist.

4. Check continuity between soft top control unit connector B67 terminal 26 and ground.

26 (LG) - Ground : Continuity should not exist.

OK or NG

- OK >> GO TO 3.
 NG >> Repair or replace harness.

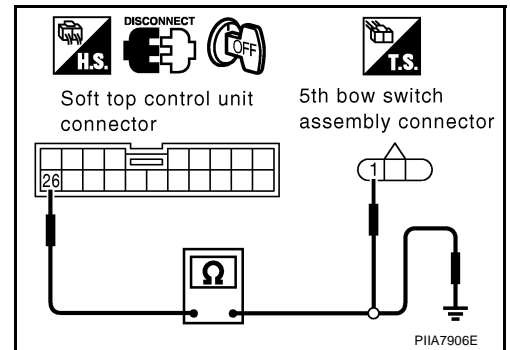

3. CHECK 5TH BOW FULL OPEN DETECTION SWITCH GROUND CIRCUIT

Check continuity between 5th bow switch assembly connector B214 terminal 3 and ground.

3 (B) - Ground : Continuity should exist.

OK or NG

- OK >> GO TO 4.
 NG >> Repair or replace harness.

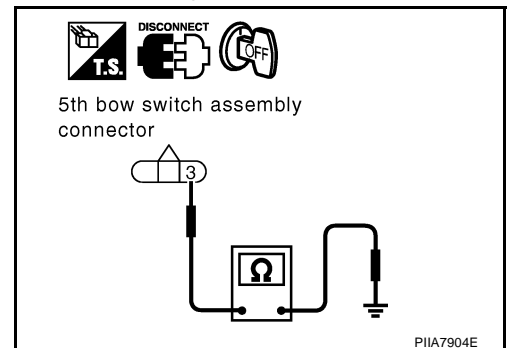

SOFT TOP

4. CHECK SOFT TOP CONTROL UNIT OUTPUT SIGNAL

1. Connect soft top control unit connector.
2. Start engine.
3. Check voltage between soft top control unit connector B67 terminal 26 and ground.

26 (LG) - Ground : Approx. 5V

OK or NG

- OK >> Replace plate rail RR.
 NG >> Replace soft top control unit.

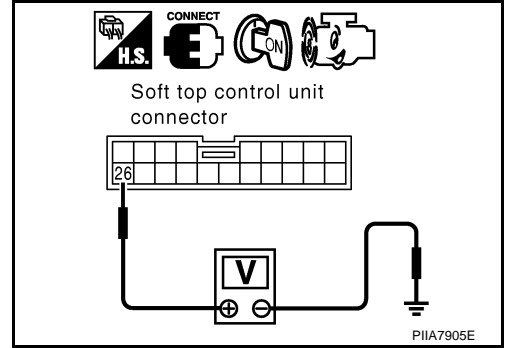

AIS0064S

5th Bow Half-Latch Switch Check (Close Operate)

1. CHECK 5TH BOW HALF-LATCH SWITCH SIGNAL CHECK

1. Start engine.
2. Operate soft top switch CLOSE, check voltage between soft top control unit connector and ground.

Connector	Terminal (Wire color)		Roof condition	Voltage (V) (Approx.)
	(+)	(-)		
B67	31 (L)	Ground	CL9 → CL10	0 → 5

OK or NG

- OK >> 5th bow half-latch switch is OK.
 NG >> GO TO 2.

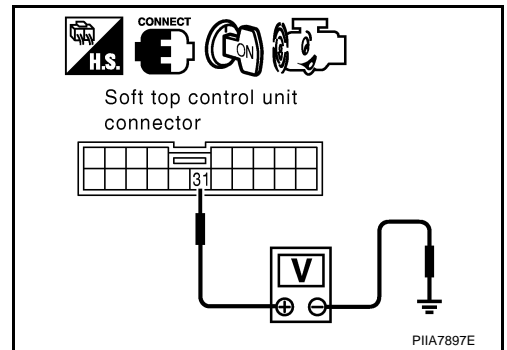

2. CHECK 5TH BOW HALF-LATCH CIRCUIT

1. Turn ignition switch OFF.
2. Disconnect soft top control unit and soft top lock switch (at 5th bow lock assembly in storage lid) connector.
3. Check continuity between soft top control unit connector B67 terminal 31 and soft top lock switch connector T205 terminal 5.

31 (L) - 5 (L) : Continuity should exist.

4. Check continuity between soft top control unit connector B67 terminal 31 and ground.

31 (L) - Ground : Continuity should not exist.

OK or NG

- OK >> GO TO 3.
 NG >> Repair or replace harness.

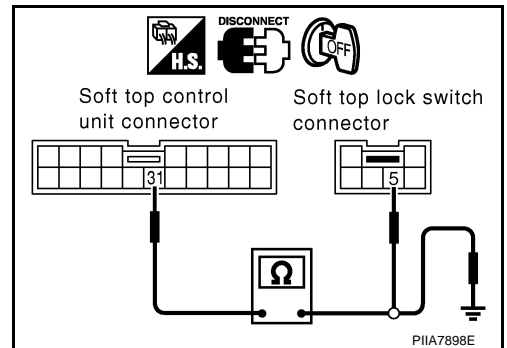

SOFT TOP

3. CHECK 5TH BOW HALF-LATCH SWITCH GROUND CIRCUIT

Check continuity between soft top lock switch connector T205 terminal 6 and ground.

6 (B) - Ground : Continuity should exist.

OK or NG

OK >> GO TO 4.

NG >> Repair or replace harness.

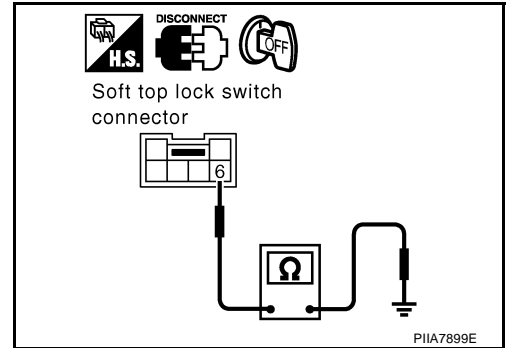

4. CHECK SOFT TOP CONTROL UNIT OUTPUT SIGNAL

1. Connect soft top control unit connector.
2. Start engine.
3. Check voltage between soft top control unit connector B67 terminal 31 and ground.

31 (L) - Ground : Approx. 5V

OK or NG

OK >> Replace 5th bow lock assembly in storage lid.

NG >> Replace soft top control unit.

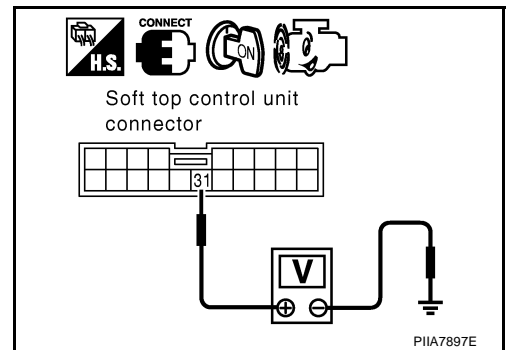

5th Bow Full-Latch Switch Check

1. CHECK 5TH BOW FULL-LATCH SWITCH SIGNAL

1. Start engine.
2. Operate soft top switch CLOSE, check voltage between soft top control unit connector and ground.

Connector	Terminal (Wire color)		Roof condition	Voltage (V) (Approx.)
	(+)	(-)		
B67	30 (Y/R)	Ground	CL10	0 → 5

OK or NG

OK >> 5th bow full-latch switch is OK.

NG >> GO TO 2.

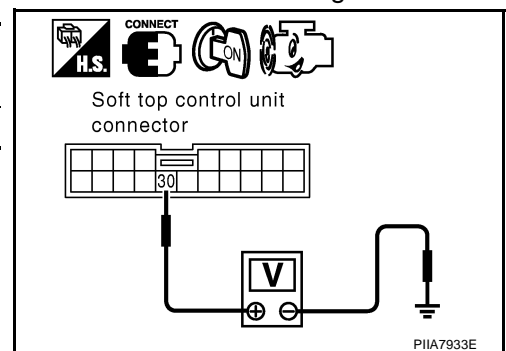

SOFT TOP

2. CHECK 5TH BOW FULL-LATCH CIRCUIT

1. Turn ignition switch OFF.
2. Disconnect soft top control unit and soft top lock switch (at 5th bow lock assembly in storage lid) connector.
3. Check continuity between soft top control unit connector B67 terminal 30 and soft top lock switch connector T205 terminal 3.

30 (Y/R) - 3 (Y) : Continuity should exist.

4. Check continuity between soft top control unit connector B67 terminal 30 and ground.

30 (Y/R) - Ground : Continuity should not exist.

OK or NG

OK >> GO TO 3.

NG >> Repair or replace harness.

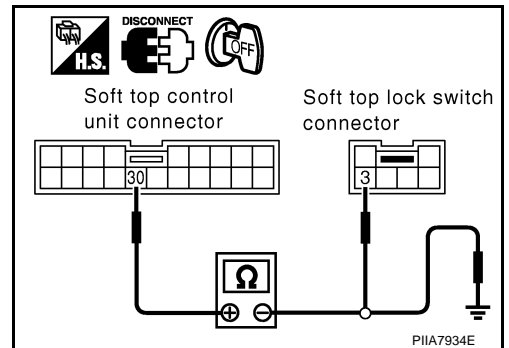

3. CHECK 5TH BOW HALF-LATCH SWITCH GROUND CIRCUIT

Check continuity between soft top lock switch connector T205 terminal 4 and ground.

4 (B) - Ground : Continuity should exist.

OK or NG

OK >> GO TO 4.

NG >> Repair or replace harness.

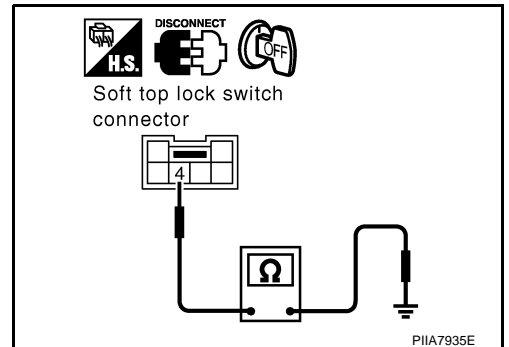

4. CHECK SOFT TOP CONTROL UNIT OUTPUT SIGNAL

1. Connect soft top control unit connector.
2. Start engine.
3. Check voltage between soft top control unit connector B67 terminal 30 and ground.

30 (Y/R) - Ground : Approx. 5V

OK or NG

OK >> Replace 5th bow assembly in storage lid.

NG >> Replace soft top control unit.

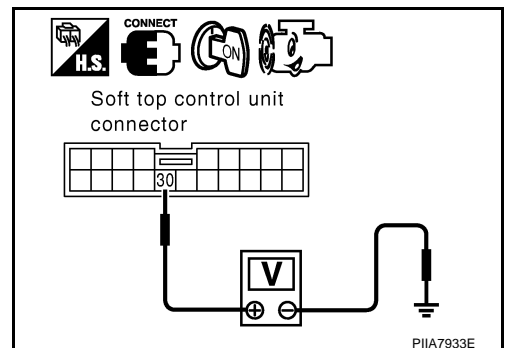

SOFT TOP

AIS0064U

5th Bow Ending Switch Check

1. CHECK 5TH BOW ENDING SWITCH SIGNAL

1. Start engine.
2. Operate soft top switch CLOSE, check voltage between soft top control unit connector and ground.

Connector	Terminal (Wire color)		Roof condition	Voltage (V) (Approx.)
	(+)	(-)		
B67	29 (R/Y)	Ground	CL10	0 → 5

OK or NG

- OK >> 5th bow ending switch is OK.
 NG >> GO TO 2.

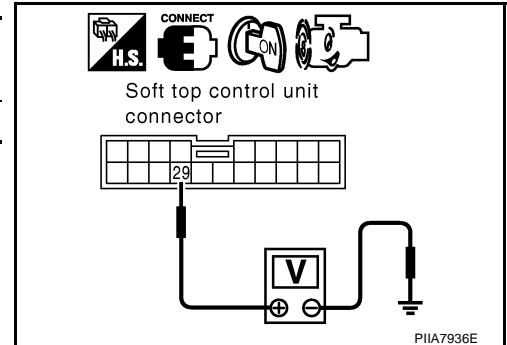

2. CHECK 5TH BOW ENDING CIRCUIT

1. Turn ignition switch OFF.
2. Disconnect soft top control unit and soft top lock switch (at 5th bow lock assembly in storage lid) connector.
3. Check continuity between soft top control unit connector B67 terminal 29 and soft top lock switch connector T205 terminal 1.

29 (R/Y) - 1 (R) : Continuity should exist.

4. Check continuity between soft top control unit connector B67 terminal 29 and ground.

29 (R/Y) - Ground : Continuity should not exist.

OK or NG

- OK >> GO TO 3.
 NG >> Repair or replace harness.

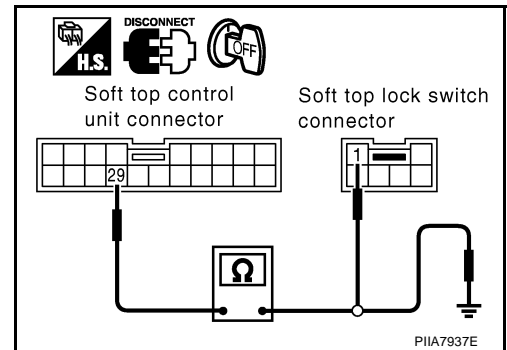

3. CHECK 5TH BOW ENDING SWITCH GROUND CIRCUIT

Check continuity between soft top lock switch connector T205 terminal 2 and ground.

2 (B) - Ground : Continuity should exist.

OK or NG

- OK >> GO TO 4.
 NG >> Repair or replace harness.

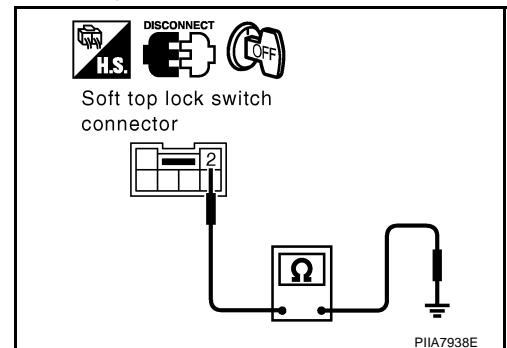

SOFT TOP

4. CHECK SOFT TOP CONTROL UNIT OUTPUT SIGNAL

1. Connect soft top control unit connector.
2. Start engine.
3. Check voltage between soft top control unit connector B67 terminal 29 and ground.

29 (R/Y) - Ground : Approx. 5V

OK or NG

- OK >> Replace 5th bow lock assembly in storage lid.
 NG >> Replace soft top control unit.

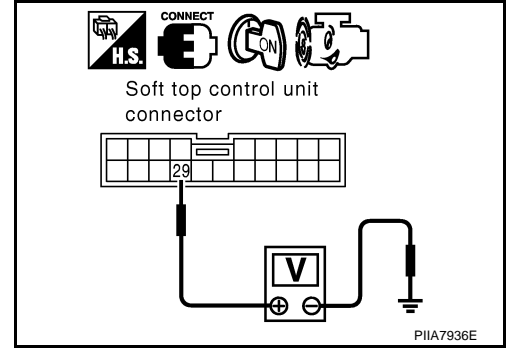

AIS0064V

5th Bow Closure Motor Check

1. 5TH BOW CLOSURE MOTOR INPUT SIGNAL

1. Start engine.
2. Operate soft top switch CLOSE, check voltage between 5th bow closure motor connector and ground.

Connector	Terminal (Wire color)		Roof condition	Voltage (V) (Approx.)
	(+)	(-)		
T204	1 (W)	Ground	CL9 → CL10	0 → Battery voltage → 0

OK or NG

- OK >> Replace 5th bow closure motor.
 NG >> GO TO 2.

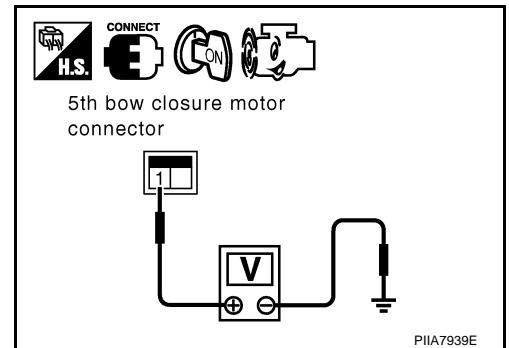

2. CHECK 5TH BOW CLOSURE MOTOR CIRCUIT

1. Turn ignition switch OFF.
2. Disconnect soft top control unit and 5th bow closure motor connector.
3. Check continuity between soft top control unit connector B66 terminal 4, 12 and 5th bow closure motor connector T204 terminal 1, 2.

4 (G/W) - 1 (W) : Continuity should exist.

12 (G/Y) - 2 (G) : Continuity should exist.

4. Check continuity between soft top control unit connector B66 terminal 4, 12 and ground.

4 (G/W) - Ground : Continuity should not exist.

12 (G/Y) - Ground : Continuity should not exist.

OK or NG

- OK >> Replace soft top control unit.
 NG >> Repair or replace harness.

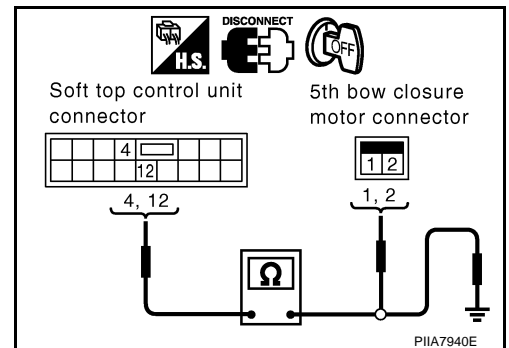

SOFT TOP

AIS0064W

Operation Permission Condition Check

First perform the "SELF-DIAG RESULT" in "BCM" with CONSULT-II, then perform the each trouble diagnosis of malfunction system indicated "SELF-DIAG RESULT" of "BCM". Refer to [BCS-11, "CONSULT-II"](#).

1. CHECK VEHICLE SPEED SIGNAL

1. Start engine.
2. Check the signal between soft top control unit connector and ground.

Connector	Terminal (Wire color)		Condition	Signal (Reference value.)
	(+)	(-)		
B66	14 (W)	Ground	Speedometer operated [When vehicle speed is Approx. 40km/h (25MPH)]	<p style="text-align: right;">PKIA1935E</p>
B67	23 (W/G)			<p style="text-align: right;">PIIB0078J</p>

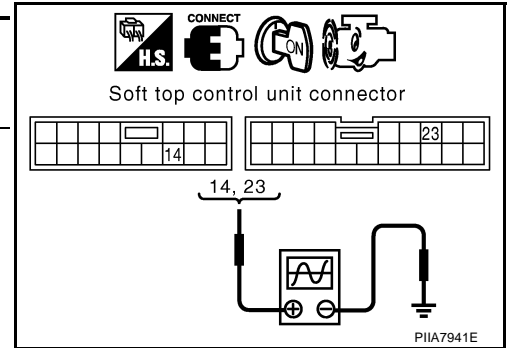

OK or NG

- OK >> GO TO 3.
 NG >> GO TO 2.

SOFT TOP

2. CHECK VEHICLE SPEED SIGNAL CIRCUIT

1. Turn ignition switch OFF.
2. Disconnect soft top control unit and unified meter and A/C amp connector.
3. Check the following.

- Continuity between soft top control unit connector B66 terminal 14 and unified meter and A/C amp connector M49 terminal 26.

14 (W) - 26 (W) : Continuity should exist.

- Continuity between soft top control unit connector B66 terminal 14 and ground.

14 (W) - Ground : Continuity should not exist.

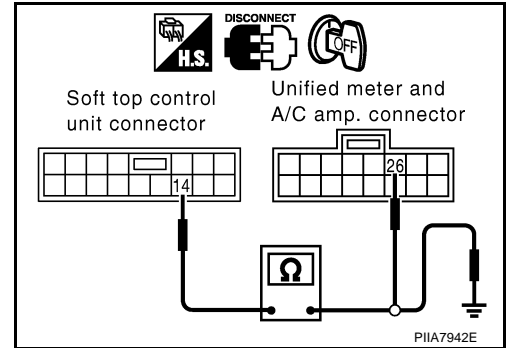

4. Check the following.

- Continuity between soft top control unit connector B67 terminal 23 and unified meter and A/C amp connector M49 terminal 34.

23 (W/G) - 34 (W/G) : Continuity should exist.

- Continuity between soft top control unit connector B67 terminal 23 and ground.

23 (W/G) - Ground : Continuity should not exist.

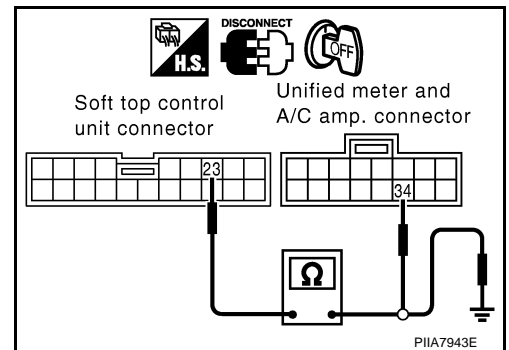

OK or NG

- OK >> Check unified meter and A/C amp. Refer to [DI-58, "System Description"](#).
- NG >> Repair or replace harness.

3. CHECK FUSE

- Check 10A fuse [No.20, located in fuse block (J/B)].

NOTE:

Refer to [RF-11, "Component Parts and Harness Connector Location"](#).

OK or NG

- OK >> GO TO 4.
- NG >> If fuse blown out, be sure to eliminate cause of malfunction before installing new fuse. Refer to [PG-4, "POWER SUPPLY ROUTING CIRCUIT"](#).

4. CHECK BRAKE PEDAL SIGNAL

Check voltage between soft top control unit connector and ground.

Connector	Terminal (Wire color)		Brake pedal condition	Voltage (V) (Approx.)
	(+)	(-)		
B68	38 (P/L)	Ground	Depressed	Battery voltage
			Released	0

OK or NG

- OK >> Operation permission condition is OK.
- NG >> GO TO 5.

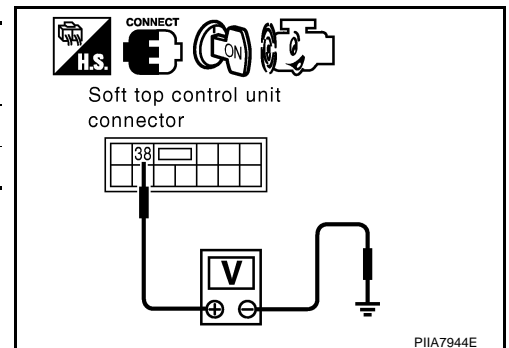

SOFT TOP

5. CHECK BRAKE PEDAL SIGNAL CIRCUIT

1. Turn ignition switch OFF.
2. Disconnect soft top control unit and stop lamp switch connector.
3. Check the following.

(M/T Models)

- Continuity between soft top control unit connector B68 terminal 38 and stop lamp switch connector E112 terminal 2.

38 (P/L) - 2 (P/L) : Continuity should exist.

- Continuity between soft top control unit connector B68 terminal 38 and ground.

38 (P/L) - Ground : Continuity should not exist.

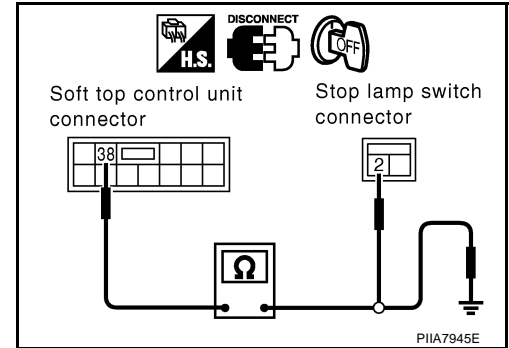

(A/T Models)

- Continuity between soft top control unit connector B68 terminal 38 and stop lamp switch connector E111 terminal 2.

38 (P/L) - 2 (P/L) : Continuity should exist.

- Continuity between soft top control unit connector B68 terminal 38 and ground.

38 (P/L) - Ground : Continuity should not exist.

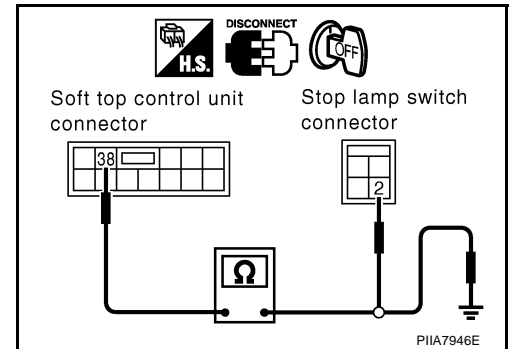

OK or NG

OK >> GO TO 6.

NG >> Repair or replace harness.

SOFT TOP

6. CHECK STOP LAMP SWITCH

1. Check the following.

(M/T Models)

- Continuity between stop lamp switch connector E112 terminal 1 and 2.

Connector	Terminal		Brake pedal condition	Continuity
	1	2		
E112	1	2	Depressed	Yes
			Released	No

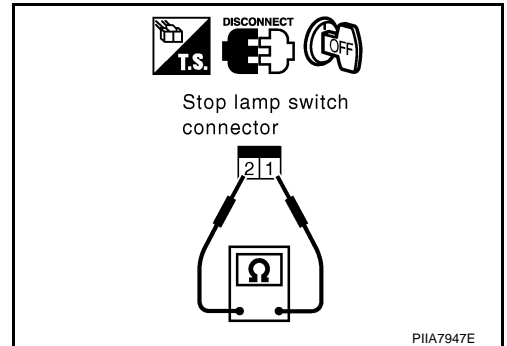

(A/T Models)

- Continuity between stop lamp switch connector E111 terminal 1 and 2.

Connector	Terminal		Brake pedal condition	Continuity
	1	2		
E111	1	2	Depressed	Yes
			Released	No

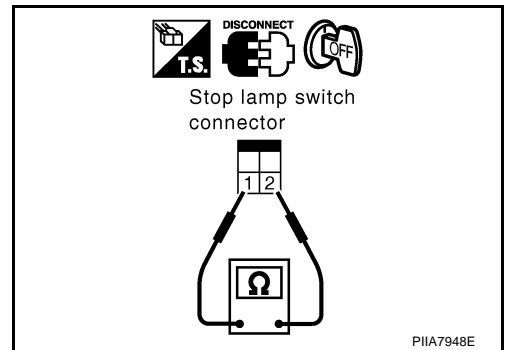

OK or NG

- OK >> Check condition of harness and connector.
- NG >> Replace stop lamp switch.

Each Switch Condition Check (Open Operate)

1. CHECK EACH SWITCH SIGNAL

1. Start engine.
2. Check voltage between soft top control unit connector and ground.

Connector	Terminal (Wire color)		Roof condition	Voltage (V) (Approx.)
	(+)	(-)		
B67	20 (W/B)	Ground	Full closed	5
	21 (W/L)			
	22 (W/R)			
	24 (G)			
	25 (L/Y)			
	26 (LG)			
	27 (W/G)			
	32 (W)			
33 (P)				

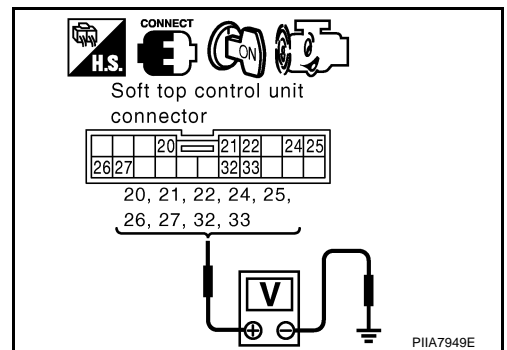

OK or NG

- OK >> Each switch condition is OK.
- NG >> Check malfunction switch.

SOFT TOP

Each Switch Condition Check (Close Operate)

AIS0064Y

1. CHECK EACH SWITCH SIGNAL

1. Start engine.
2. Check voltage between soft top control unit connector and ground.

Connector	Terminal (Wire color)		Roof condition	Voltage (V) (Approx.)
	(+)	(-)		
B67	20 (W/B)	Ground	Full opened	0
	21 (W/L)			
	22 (W/R)			
	24 (G)			5
	25 (L/Y)			
	26 (LG)			
	27 (W/G)			0
	31 (L)			
	32 (W)			
33 (P)	5			

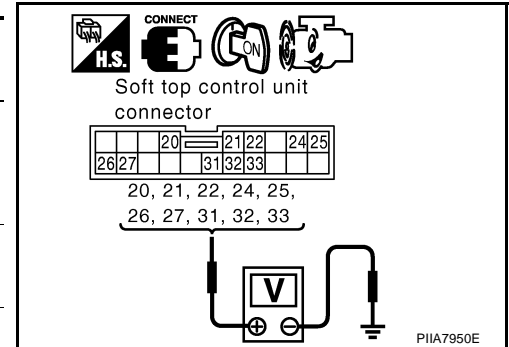

OK or NG

- OK >> Each switch condition is OK.
 NG >> Check malfunction switch.

Power Window Down Request Signal Check

AIS0064Z

1. CHECK POWER WINDOW REQUEST SIGNAL

1. Start engine.
2. Soft top switch operate, check voltage between soft top control unit connector and ground.

Connector	Terminal (Wire color)		Roof condition	Voltage (V) (Approx.)
	(+)	(-)		
B67	36 (Y/G)	Ground	OP1 → OP11	5 → 0 → 5
			CL1 → CL10	

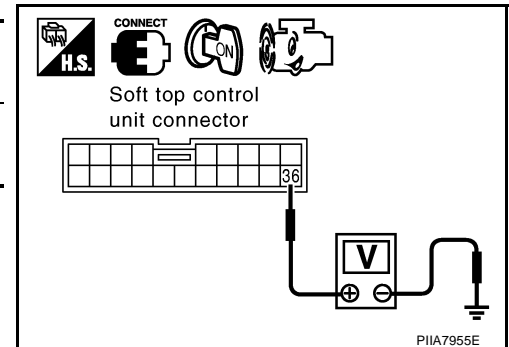

OK or NG

- OK >> Check the condition of harness and connector.
 NG >> Replace soft top control unit.

Power Window Harness Check

AIS00650

1. CHECK POWER WINDOW CIRCUIT

1. Turn ignition switch OFF.
2. Disconnect soft top control unit, power window main switch and power window sub-switch connector.
3. Check the following.

- Continuity between soft top control unit connector B67 terminal 36 and power window main switch connector D7 terminal 4.

36 (Y/G) - 4 (B/R) : Continuity should exist.

- Continuity between soft top control unit connector B67 terminal 36 and ground.

36 (Y/G) - Ground : Continuity should not exist.

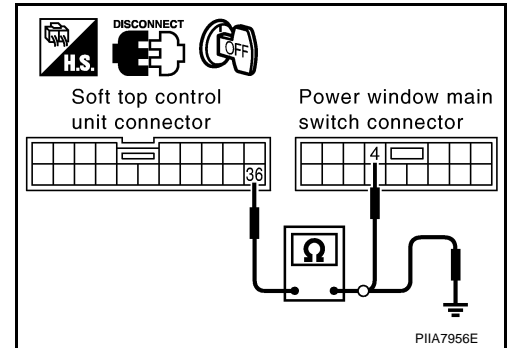

4. Check the following.

- Continuity between soft top control unit connector B67 terminal 36 and power window sub-switch connector D37 terminal 13.

36 (Y/G) - 13 (P) : Continuity should exist.

OK or NG

- OK >> Replace malfunction power window switch.
- NG >> Repair or replace harness.

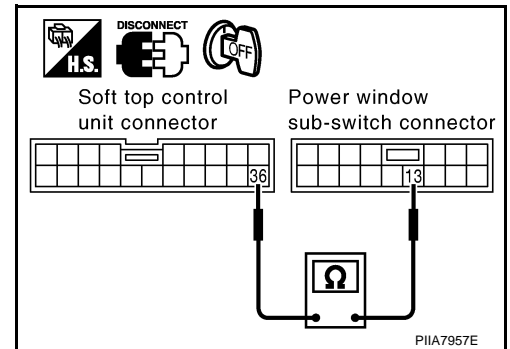

Passenger Side Seat Operate Signal Check 1

AIS00651

1. CHECK PASSENGER SIDE SEAT CIRCUIT

1. Turn ignition switch OFF.
2. Disconnect soft top control unit and passenger side seat control unit connector.

3. Check continuity between soft top control unit connector B67 terminal 36 and passenger side seat control unit connector B353 terminal 16.

36 (Y/G) - 16 (PU/W) : Continuity should exist.

4. Check continuity between soft top control unit connector B67 terminal 36 and ground.

36 (Y/G) - Ground : Continuity should not exist.

OK or NG

- OK >> Replace passenger side seat control unit.
- NG >> Repair or replace harness.

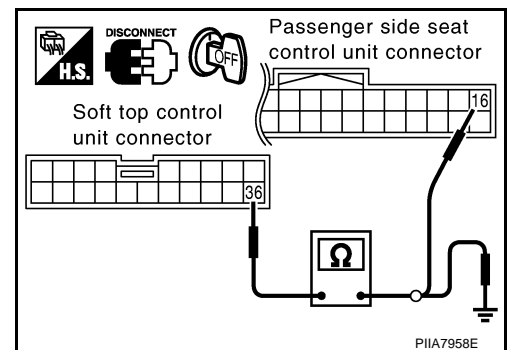

SOFT TOP

Passenger Side Seat Operate Signal Check 2

AIS00652

1. CHECK PASSENGER SIDE SEAT CIRCUIT

1. Turn ignition switch OFF.
2. Disconnect soft top control unit, storage lid actuator RH and passenger side seat control unit connector.
3. Check continuity between soft top control unit connector B66 terminal 13 and passenger side seat control unit connector B354 terminal 33.

13 (L/R) - 33 (G/B) : Continuity should exist.

4. Check continuity between soft top control unit connector B66 terminal 13 and ground.

13 (L/R) - Ground : Continuity should not exist.

OK or NG

- OK >> Replace passenger side seat control unit.
 NG >> Repair or replace harness.

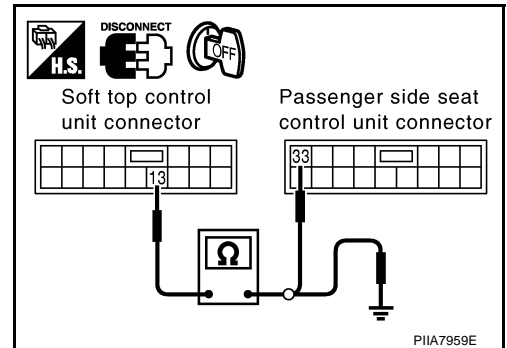

PIIA7959E

Passenger Side Seat Operate Signal Check 3

AIS00653

1. CHECK PASSENGER SIDE SEAT CIRCUIT

1. Turn ignition switch OFF.
2. Disconnect soft top control unit, passenger side seat control unit and soft top lock switch connector.
3. Check continuity between soft top control unit connector B67 terminal 30 and passenger side seat control unit connector B353 terminal 11.

30 (Y/R) - 11 (L/W) : Continuity should exist.

4. Check continuity between soft top control unit connector B67 terminal 30 and ground.

30 (Y/R) - Ground : Continuity should not exist.

OK or NG

- OK >> Replace passenger side seat control unit.
 NG >> Repair or replace harness.

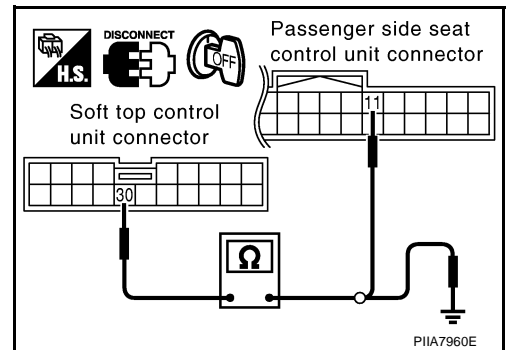

PIIA7960E

Seat Back Position Signal Check

AIS00654

1. CHECK SEAT BACK POSITION SIGNAL

1. Start engine.
2. The thing whose seat cancel switch is OFF is confirmed.
3. Soft top switch operate, check voltage between soft top control unit connector and ground.

Connector	Terminal (Wire color)		Seat condition	Voltage (V) (Approx.)
	(+)	(-)		
B67	34 (L/W)	Ground	When passenger seat inclines forward	5
			Other than above	0

OK or NG

- OK >> Replace soft top control unit.
 NG >> GO TO 2.

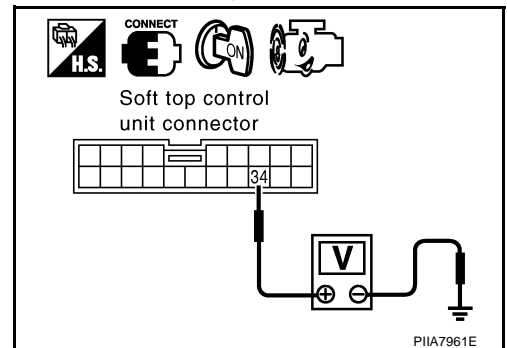

PIIA7961E

SOFT TOP

2. CHECK SEAT BACK POSITION SIGNAL CIRCUIT

1. Turn ignition switch OFF.
2. Disconnect soft top control unit and passenger side seat control unit connector.
3. Check continuity between soft top control unit connector B67 terminal 34 and passenger side seat control unit connector B353 terminal 32.

34 (L/W) - 32 (G/W) : Continuity should exist.

4. Check continuity between soft top control unit connector B67 terminal 34 and ground.

34 (L/W) - Ground : Continuity should not exist.

OK or NG

OK >> Check passenger side seat. Refer to [SE-32, "Trouble Diagnosis Symptom Chart"](#).

NG >> Repair or replace harness.

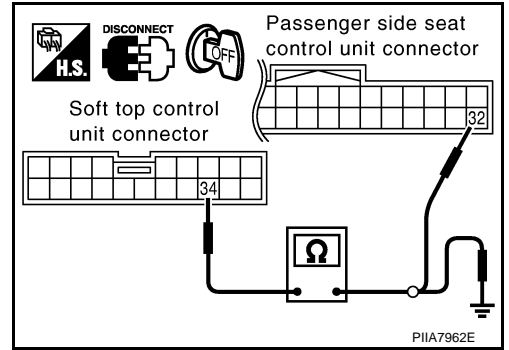

Speed Signal Circuit Check

AIS00655

First perform the "SELF-DIAG RESULT" in "BCM" with CONSULT-II, then perform the each trouble diagnosis of malfunction system indicated "SELF-DIAG RESULT" of "BCM". Refer to [BCS-11, "CONSULT-II"](#).

1. CHECK VEHICLE SPEED SIGNAL

1. Start engine.
2. Check the signal between soft top control unit connector and ground.

Connector	Terminal (Wire color)		Condition	Signal (Reference value.)
	(+)	(-)		
B66	14 (W)	Ground	Speedometer operated [When vehicle speed is Approx. 40km/h (25MPH)]	
B67	23 (W/G)			

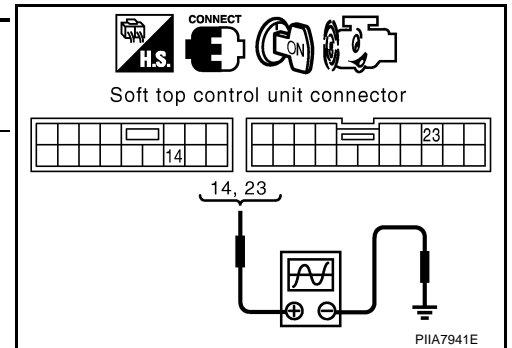

OK or NG

OK >> Replace soft top control unit.

NG >> GO TO 2.

SOFT TOP

2. CHECK VEHICLE SPEED SIGNAL CIRCUIT

1. Turn ignition switch OFF.
2. Disconnect soft top control unit and unified meter and A/C amp connector.
3. Check the following.

- Continuity between soft top control unit connector B66 terminal 14 and unified meter and A/C amp connector M49 terminal 26.

14 (W) - 26 (W) : Continuity should exist.

- Continuity between soft top control unit connector B66 terminal 14 and ground.

14 (W) - Ground : Continuity should not exist.

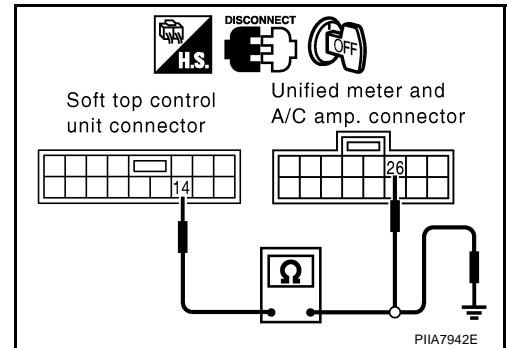

4. Check the following.

- Continuity between soft top control unit connector B67 terminal 23 and unified meter and A/C amp connector M49 terminal 34.

23 (W/G) - 34 (W/G) : Continuity should exist.

- Continuity between soft top control unit connector B67 terminal 23 and ground.

23 (W/G) - Ground : Continuity should not exist.

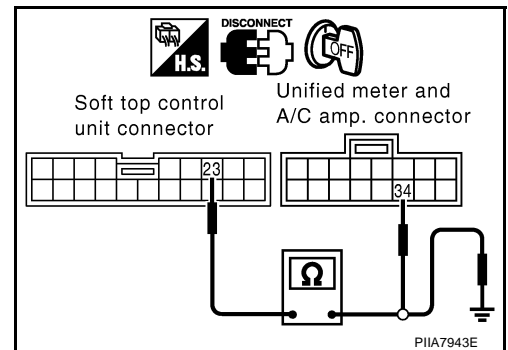

OK or NG

- OK >> Check unified meter and A/C amp. Refer to [DI-58, "System Description"](#).
- NG >> Repair or replace harness.

Indicator Lamp Circuit Check

1. CHECK FUSE

- Check 10A fuse [No.14, located in fuse block (J/B)]

NOTE:

Refer to [RF-11, "Component Parts and Harness Connector Location"](#).

OK or NG

- OK >> GO TO 3.
- NG >> If fuse blown out, be sure to eliminate cause of malfunction before installing new fuse. Refer to [PG-4, "POWER SUPPLY ROUTING CIRCUIT"](#).

2. CHECK INDICATOR LAMP SIGNAL

1. Start engine.
2. Soft top switch operate, check voltage between soft top control unit connector and ground.

Connector	Terminal (Wire color)		Roof condition	Voltage (V) (Approx.)
	(+)	(-)		
B67	35 (BR)	Ground	In position on the way	0
			Full open or full close	Battery voltage

OK or NG

- OK >> Check the condition of the harness and the connector.
- NG - 1 >> If battery voltage : Replace soft top control unit.
- NG - 2 >> If 0V : GO TO 3.

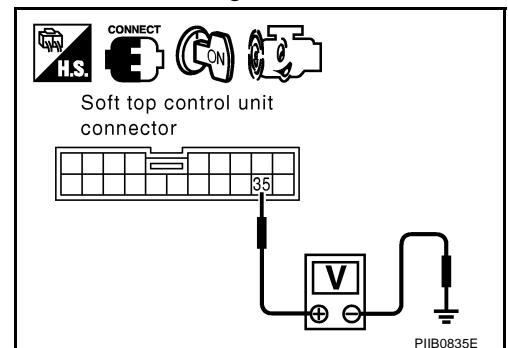

SOFT TOP

3. CHECK INDICATOR LAMP CIRCUIT

1. Turn ignition switch OFF.
2. Disconnect soft top control unit and combination meter connector.
3. Check continuity between soft top control unit connector B67 terminal 35 and combination meter connector M19 terminal 13.

35 (BR) – 13 (G/W) : Continuity should exist.

4. Check continuity between soft top control unit connector B67 terminal 35 and ground.

35 (BR) – Ground : Continuity should not exist.

OK or NG

OK >> GO TO 4.

NG >> Repair or replace harness.

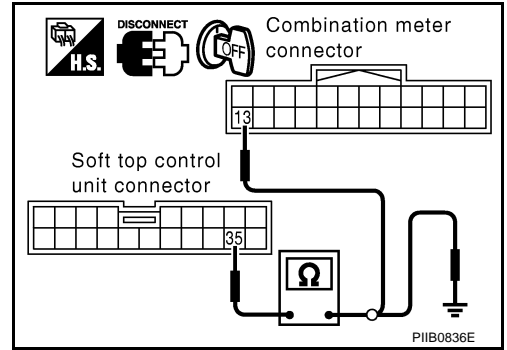

4. CHECK INDICATOR LAMP POWER SUPPLY

1. Turn ignition switch ON.
2. Check voltage between combination meter connector M19 terminal 23 and ground.

23 (G/Y) – Ground : Battery voltage

OK or NG

OK >> Check the Condition of the Harness and the Connector.

- If OK : Replace combination meter.

- If NG : Repair or replace harness.

NG >> Repair or replace harness.

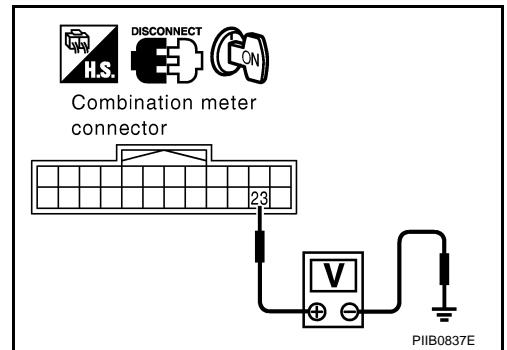

Removal and Installation of Soft Top Control Unit

REMOVAL

1. Push the soft top switch on the close side to clear the soft top strage room, and release the buttom before strage lid starts closing.
2. Remove trim parts and turn the front side of storage room finisher. [RF-125. "Removal and Installation of Storage Room Finisher"](#)
3. Disconnect soft top control unit connector, remove the screw and soft top control unit.

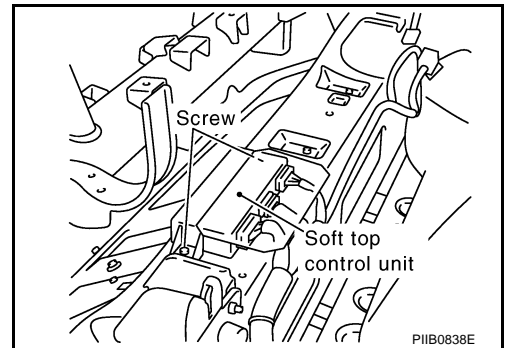

INSTALLATION

Installation in the reverse order of removal.

SOFT TOP

Component Parts Drawing

AIS00658

SEC. 737

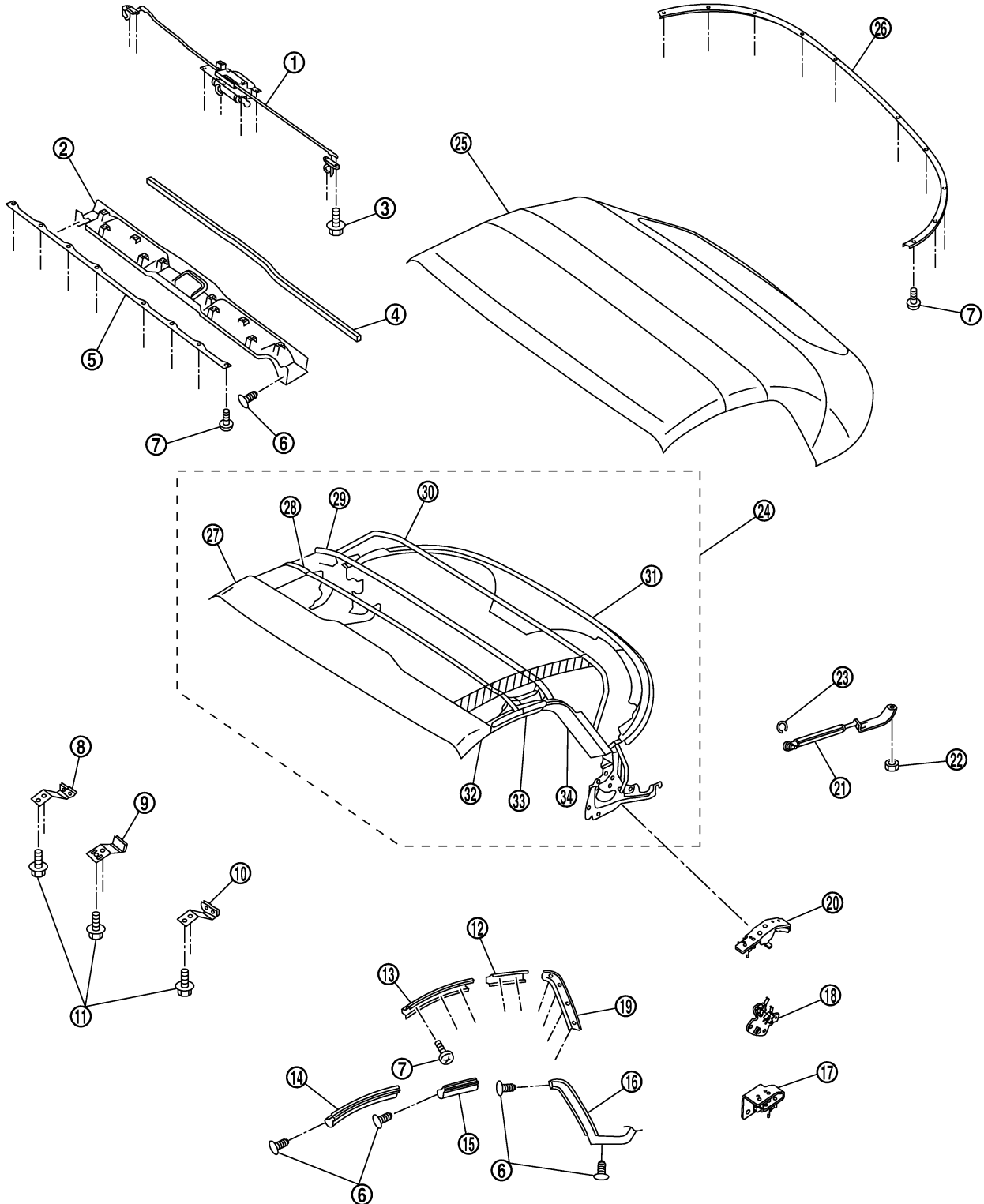

PIIB1399E

RF-86

SOFT TOP

- | | | |
|-------------------------------------|-------------------------------|---------------------------------|
| 1. Front lock | 2. Front lock finisher | 3. TORX bolt (T30) |
| 4. Welt | 5. Front center retainer | 6. Clip |
| 7. Screw | 8. Front lock striker, RH | 9. Front lock striker, center |
| 10. Front lock striker, LH | 11. Bolt | 12. B link retainer |
| 13. A link retainer | 14. A link weatherstrip | 15. B link weatherstrip |
| 16. C link and 5th bow weatherstrip | 17. Soft top switch bracket 1 | 18. Soft top switch bracket 2 |
| 19. C link retainer | 20. Plate rail RR bracket | 21. 5th bow operating strut rod |
| 22. Nut | 23. Holder | 24. Soft top frame |
| 25. Soft top cover | 26. 5th bow retainer | 27. 1st bow |
| 28. 2nd bow | 29. 3rd bow | 30. 4th bow |
| 31. 5th bow | 32. A link | 33. B link |
| 34. C link | | |

A
B
C
D
E
F
G
H
RF
J
K
L
M

Removal and Installation of Soft Top Assembly

AIS00659

CAUTION:

Install fender cover to protect rear fender.

REMOVAL

1. Fully open storage lid with soft top retracting.
2. Remove seat belt sholder bolt. Refer to [SB-4, "REMOVAL OF SEAT BELT RETRACTOR"](#) .
3. Remove rear side finisher. Refer to [EI-29, "REAR SIDE FINISHER"](#) .
4. Remove back panel finisher. Refer to [EI-32, "BACK PANEL FINISHER"](#) .
5. Loosen bolts at soft top mounting bracket (front).

CAUTION:

Do not remove soft top mounting bracket (front) (body side).

 **Nut : 28.0 N·m (2.9 kg·m, 21 ft·lb)**

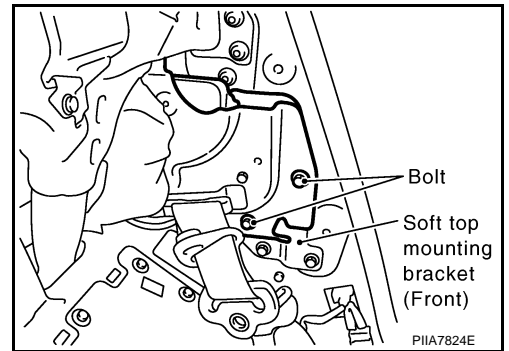

6. Close soft top until 5th bow are raised and folded with C-link. Loosen nut at soft top mounting bracket (rear). Then fold (open) soft top assembly completely.

CAUTION:

Do not remove soft top mounting bracket (rear) (body side).

 **Bolt : 28.0 N·m (2.9 kg·m, 21 ft·lb)**

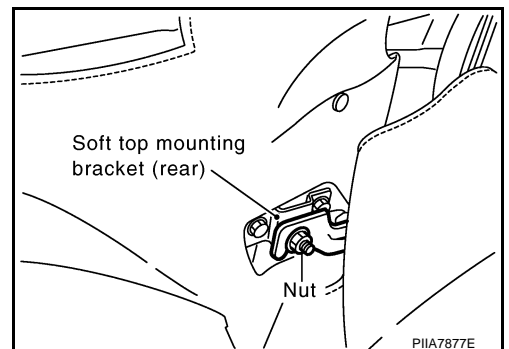

7. Remove back panel bracket.

SOFT TOP

8. Remove bolts, at the soft top mounting plate and shims.

CAUTION:

Do not replace left and right shims with each one with different thickness.

 Bolt: 28.0 N-m (2.9 kg-m, 21 ft-lb)

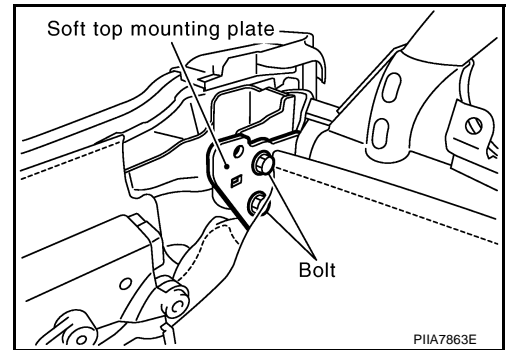

9. Disconnect harness connector.

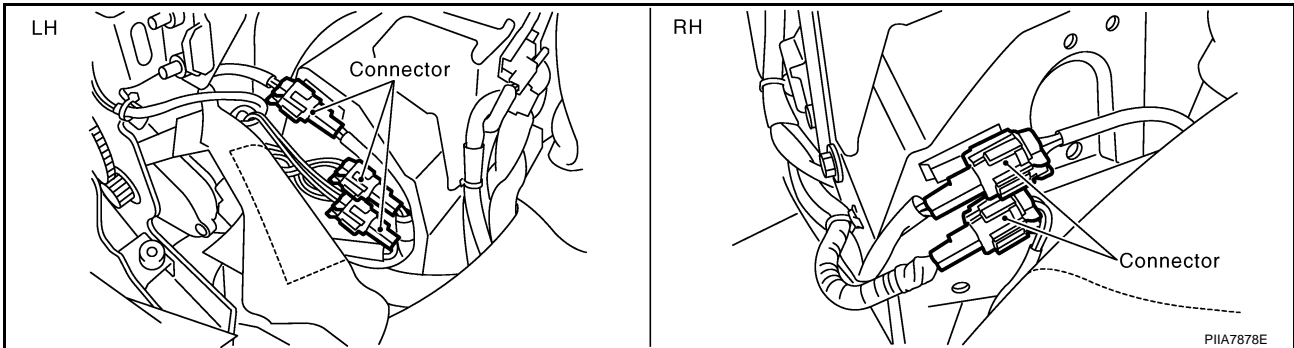

10. Lift up soft top assembly from left and right, and then remove soft top assembly

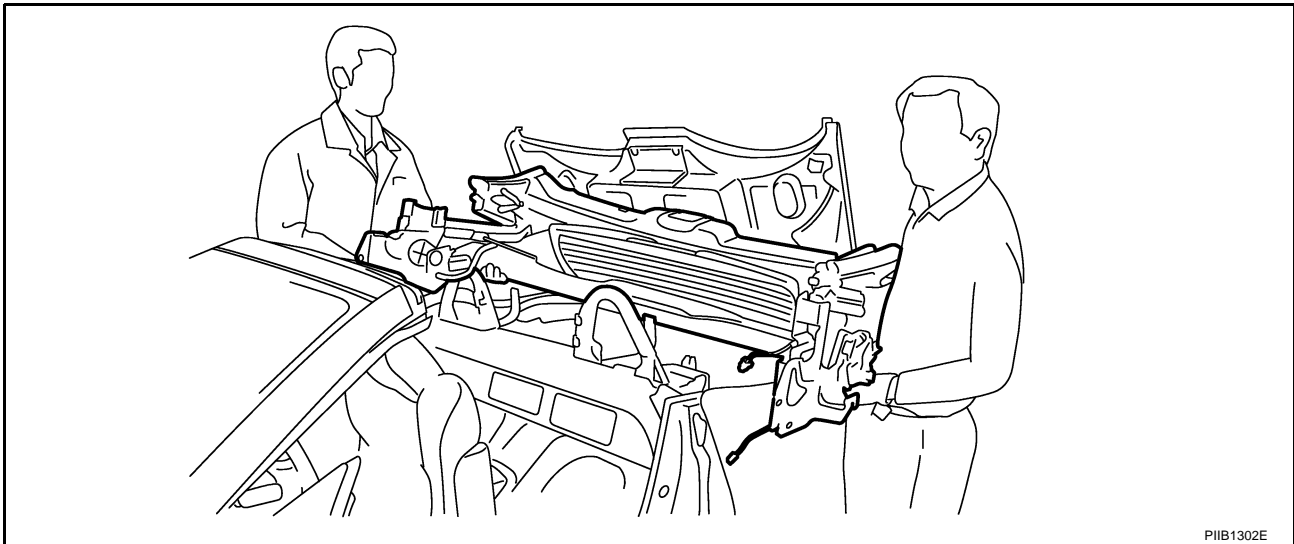

CAUTION:

2 workers are required for the heavy load of approximately 40 kg (89 lb).

INSTALLATION

Install in the reverse order of removal except the order of tightening bolts and nuts. (See note below.)

NOTE:

- Before tighten soft top fixing bolts and nuts, make sure that soft top is sat on each pins from soft top mounting brackets without any gaps.
To sit soft top correctly, follow this order.
 1. Push soft top assembly down when nuts at soft top mounting bracket (rear) is tighten.
 2. Close soft top until the angle of A-link becomes vertical against ground, then tighten bolts at soft top mounting bracket (front).
 3. Tighten bolts at soft top mounting plate with shims, then attach back panel bracket with bolts.

SOFT TOP

Removal and Installation of Soft Top Cover

AIS0065A

REMOVAL

CAUTION:

- Do not reuse used double-faced adhesive tape, nonwoven fabric, EPT seal, pad, etc.
 - Be careful not to damage soft top assembly during removal. Do not place it upside-down so as to prevent cover from compression scars.
1. Remove soft top assembly from the vehicle. Refer to [RF-87, "Removal and Installation of Soft Top Assembly"](#).
 2. Set up the soft top assembly on the table.

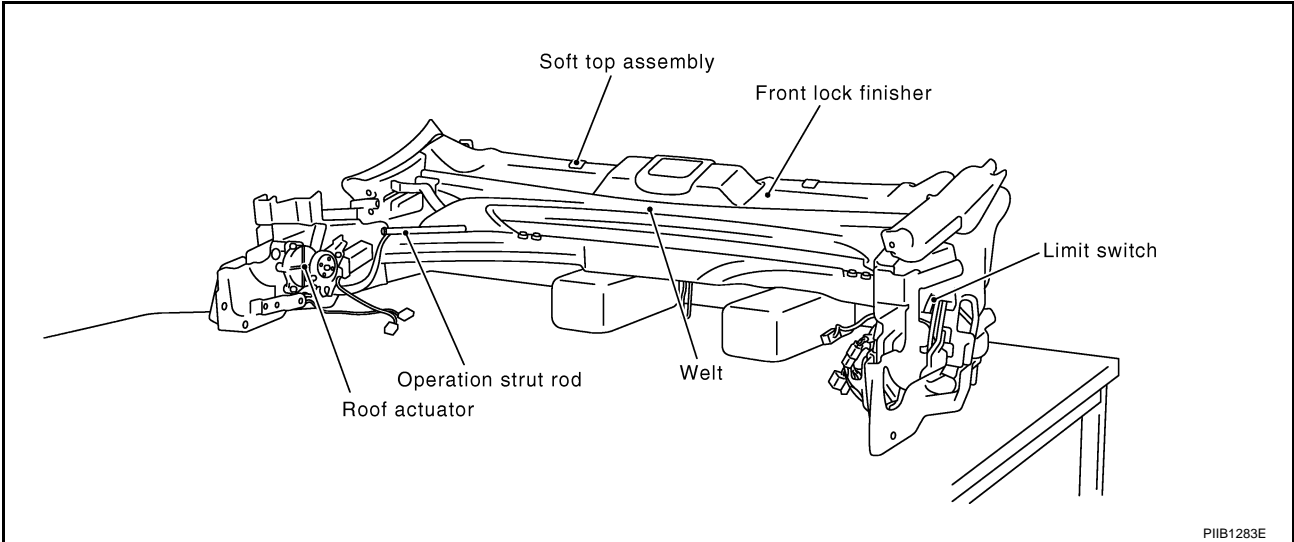

3. Remove roof actuator (RH/LH). Refer to [RF-107, "Removal and Installation of Roof Actuator"](#).
4. Remove holder of 5th bow operation strut rods, and then remove 5th bow operation strut rods.

CAUTION:

- When 5th bow operating strut rods are removed, 5th bow drops suddenly.
Perform operation while holding 5th bow.

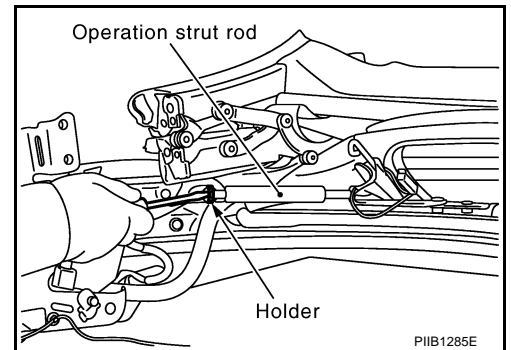

- Temporarily fix 5th bow operating strut rods on 5th bow finisher after removal.

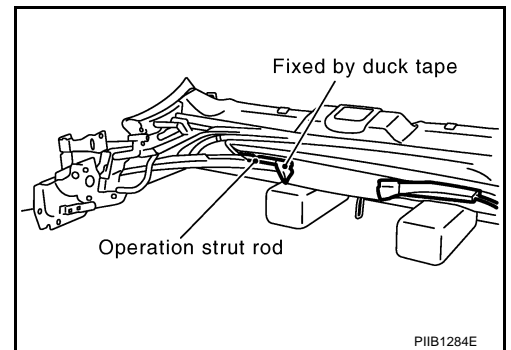

A
B
C
D
E
F
G
H
RF
J
K
L
M

SOFT TOP

5. Open soft top assembly.

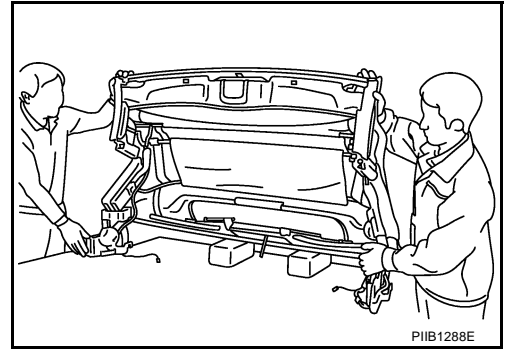

6. Protect the limit switch contact around the rotation axis of the 5th bow on the left side of soft top with tape.

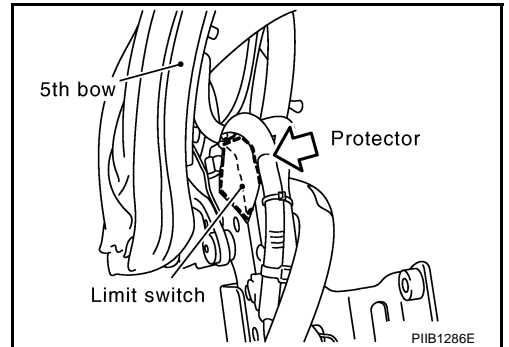

7. Remove welt on the rear end of front lock finisher.

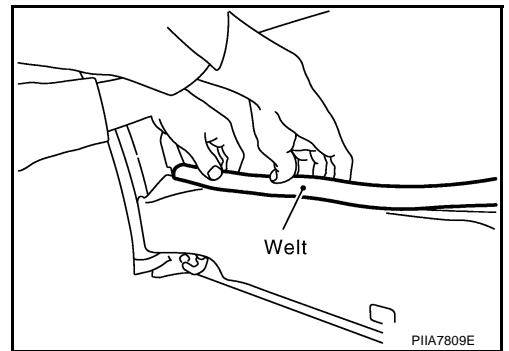

8. Remove left/right clips on the front end of front lock finisher.

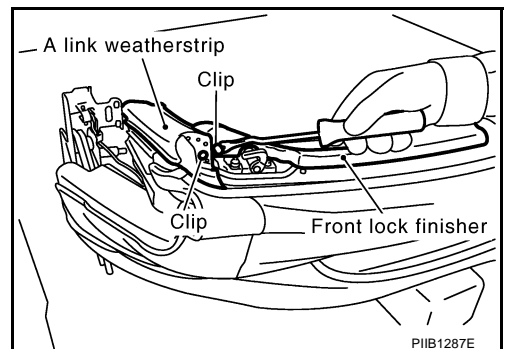

9. Pull up front lock lever, and then disengage clips to remove front lock finisher.

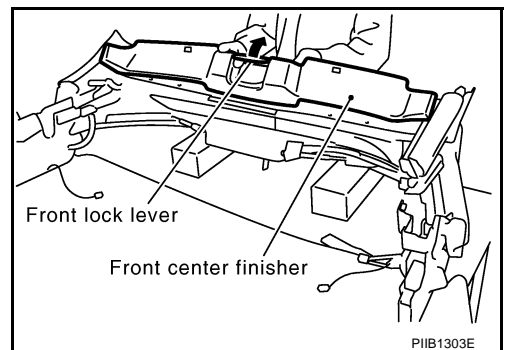

SOFT TOP

10. Remove clip, and then A link weatherstrip.

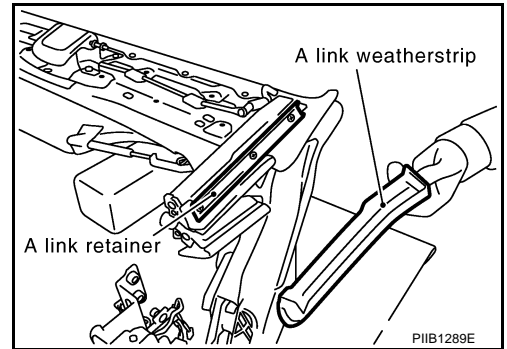

11. Peel a link sealing out.

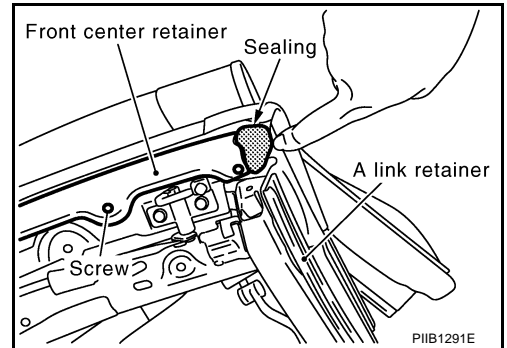

12. Remove screws, and then remove front center retainer.

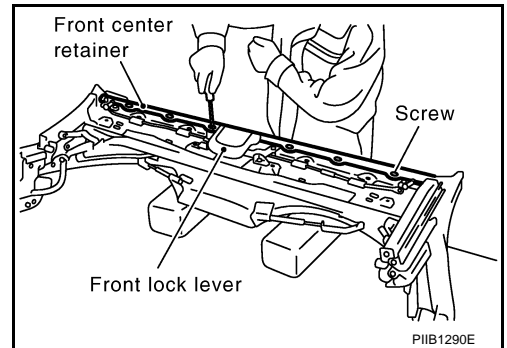

13. Put matching marks to installation position of A link retainer.

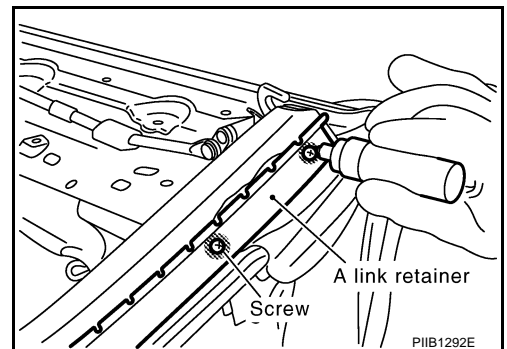

14. Remove screws, and then remove A link retainer.

A
B
C
D
E
F
G
H
RF
J
K
L
M

SOFT TOP

15. Open soft top about 90 degrees.

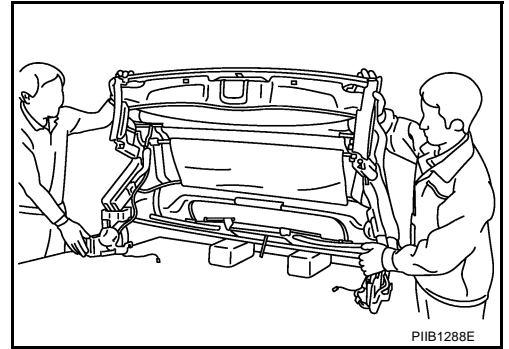

16. Remove clips on the top of C link and 5th bow weatherstrip.

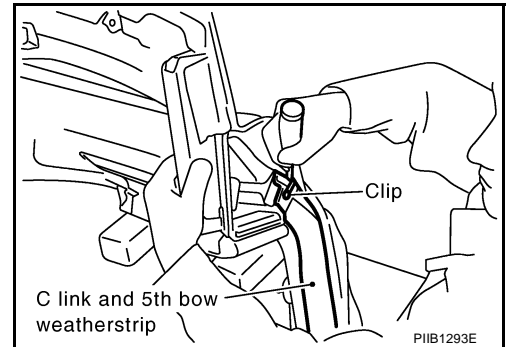

17. Fully open soft top.

18. Put matching marks to installation position on C link retainer.

19. Remove screws, and then remove C link retainer.

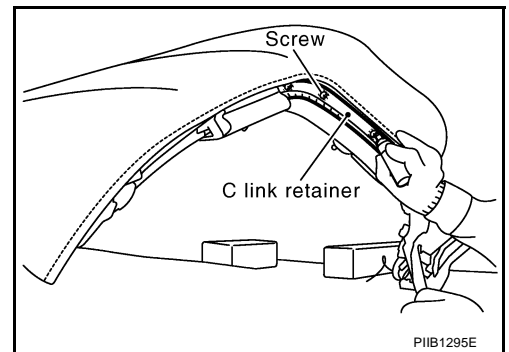

20. Remove clips on the bottom edge of C link and 5th bow weatherstrip.

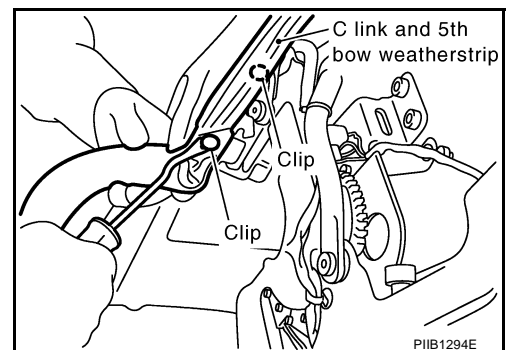

SOFT TOP

21. Remove C link and 5th bow weatherstrip from 5th bow.

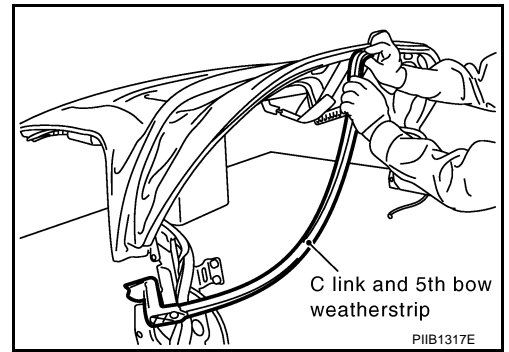

22. Remove screws, and then remove 5th bow retainer.

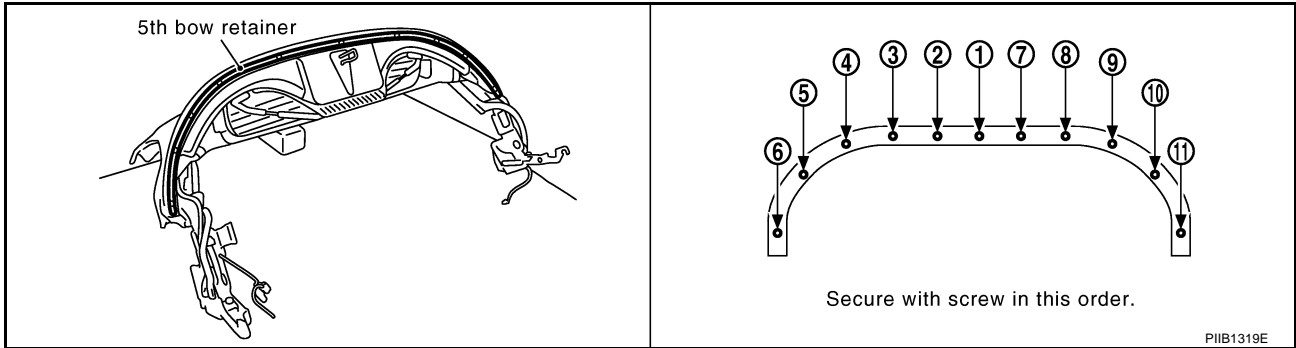

23. Shave rivets head of soft top cover 5th bow by using a drill.
[Drill bit diameter: 5.5 mm (0.22 in)]

CAUTION:
Do not attempt to remove rivets completely.

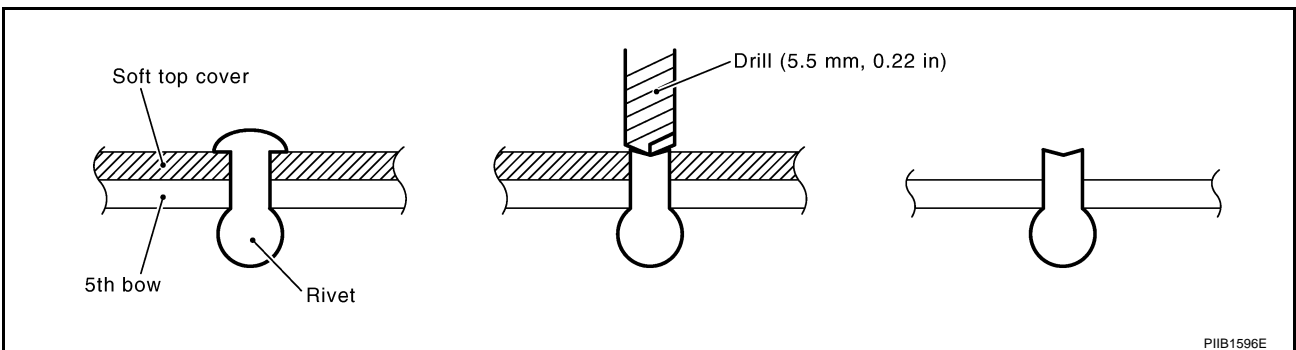
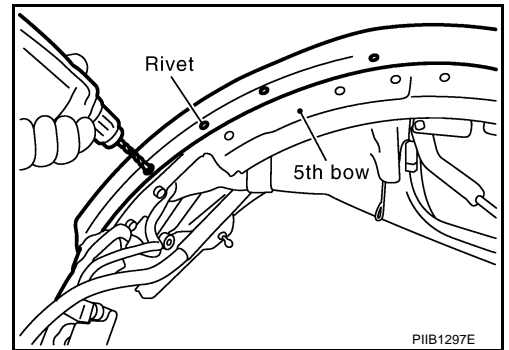

A
B
C
D
E
F
G
H
RF
J
K
L
M

SOFT TOP

24. Close soft top, and then Shave rivets head and of C link by using a drill.
[Drill bit diameter: 5.5 mm (0.22 in)]

CAUTION:

Do not attempt to remove rivets completely.

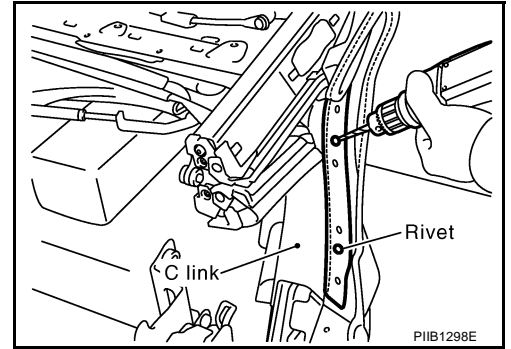

25. Cut EPT seal and remove screws on the bottom of C link.

NOTE:

Check the position when cutting EPT seal.

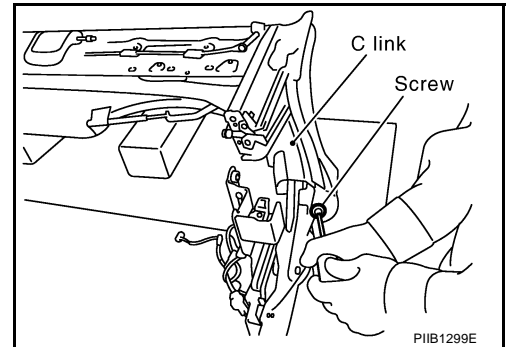

26. Pull up soft top cover from 5th bow finisher.

27. Shave rivets head of 5th bow finisher upper surface, and then remove rivets head and remove retainer.
[Drill bit diameter: 5.5 mm (0.22 in)]

CAUTION:

- Do not attempt to remove rivets completely.
- Be careful not to damage soft top when using a drill.

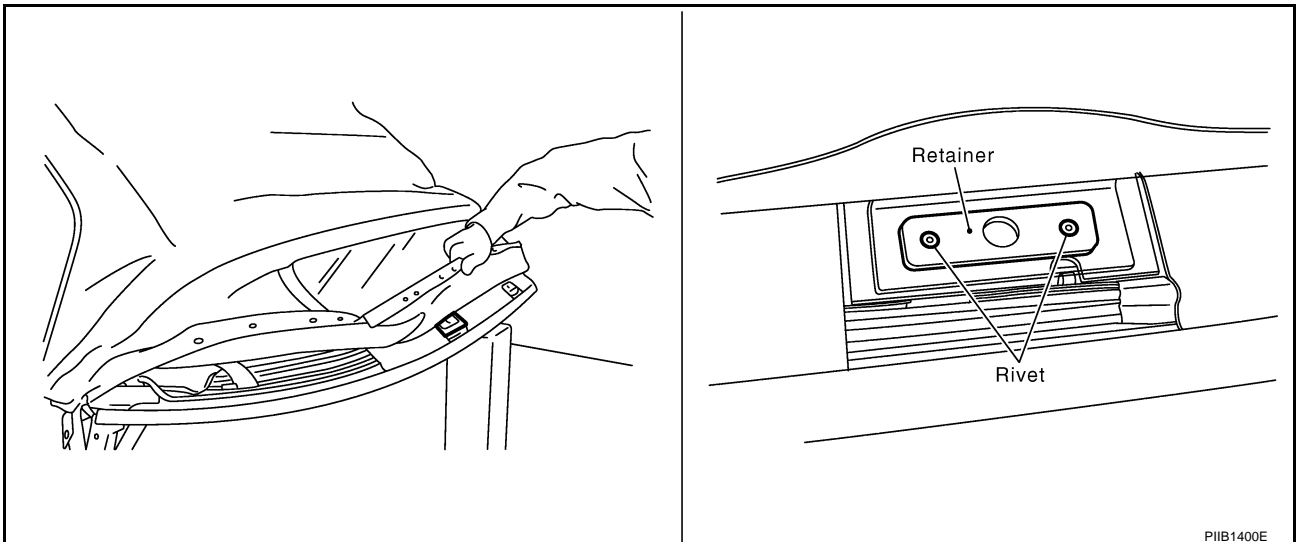

28. Pull up cover from the bottom of C link.

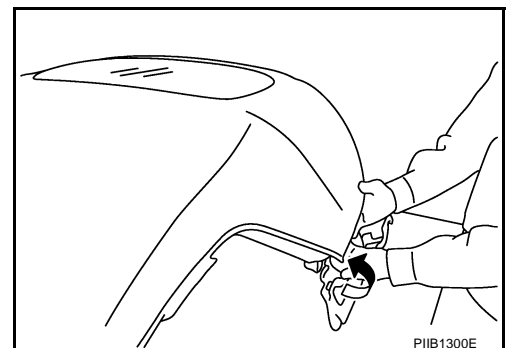

SOFT TOP

29. Open harness connector cover, and then disconnect defogger harness connector from terminal.

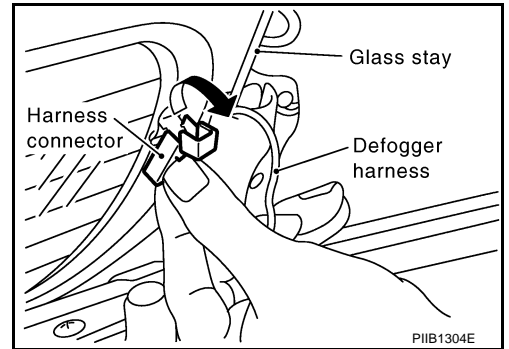

30. Open soft top about 90 degrees.

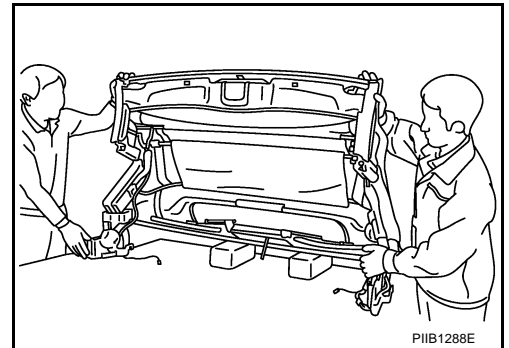

31. Remove soft top wire from A link.

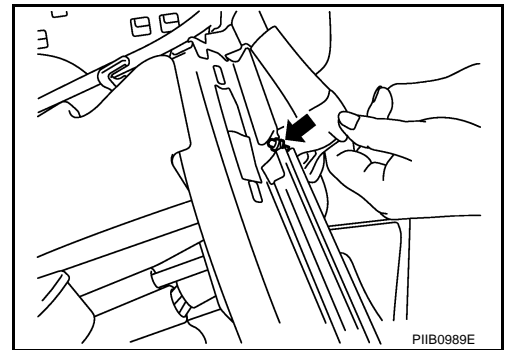

32. Remove soft top cover wire rear bracket from C link.
33. Remove spring from C link.

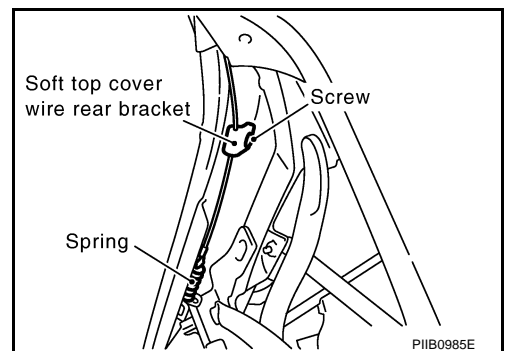

34. Pull out soft top cover frontward from 1st bow.

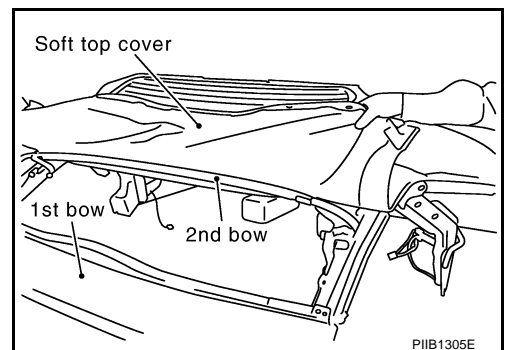

A
B
C
D
E
F
G
H
RF
J
K
L
M

SOFT TOP

35. Pull up 2nd bow retainer by using a screwdriver, and then remove soft top cover from 2nd bow.

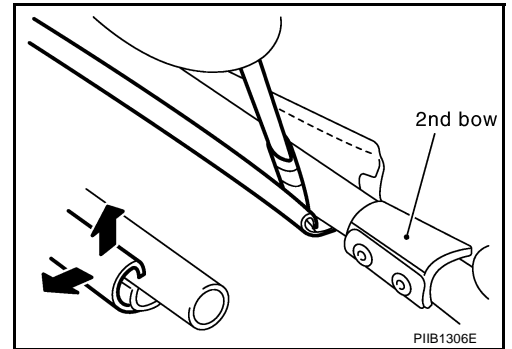

36. Pull up 3rd bow retainer by using a screwdriver, and then remove soft top cover from 3rd bow.
37. Pull out glass stay and defogger harness from sleeve on rear window glass side.

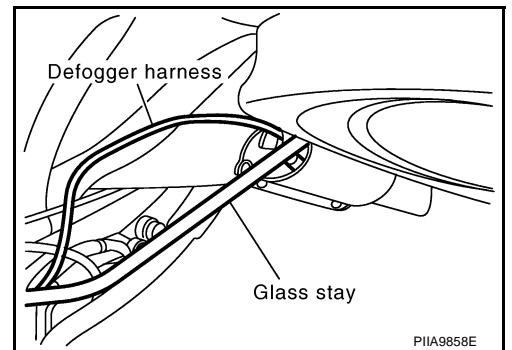

38. Pull out soft top cover from 4th bow and remove soft top cover completely from frame.

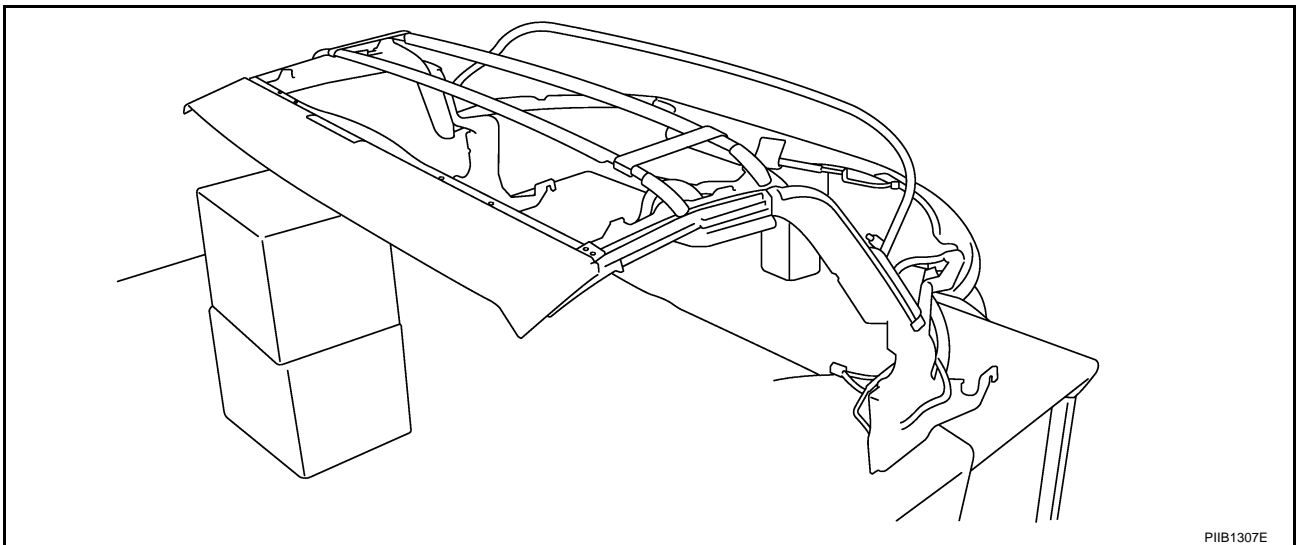

INSTALLATION

CAUTION:

Make sure that the limit switch contact around the rotation axis of the 5th bow on the left side of soft top is protected with tape.

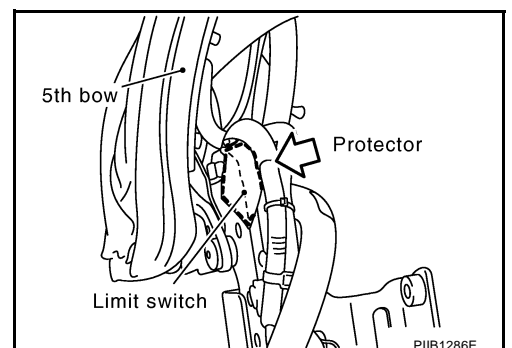

SOFT TOP

Preparation Work

1. Remove 5th bow finisher pads.

NOTE:

Put matching marks so as to check the position when installing.

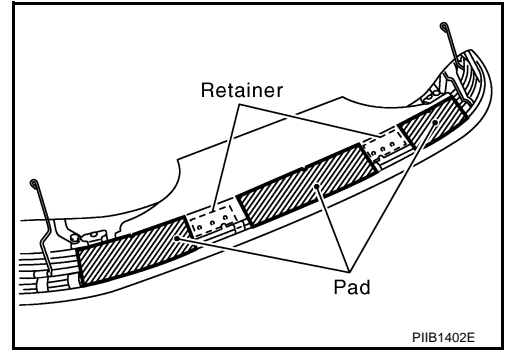

2. Remove screws, and then remove 5th bow side finisher (RH/LH).

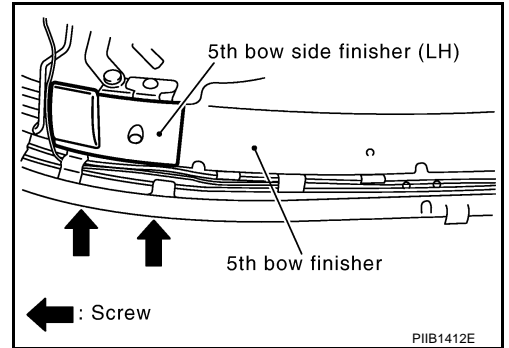

3. Remove clips, and then remove 5th bow finisher.

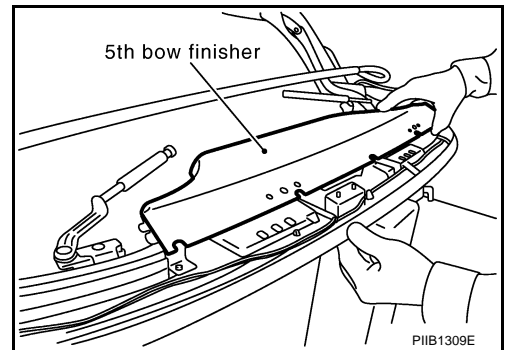

4. Remove rivets head of 5th bow finisher retainer.

CAUTION:

Do not attempt to remove rivets completely.

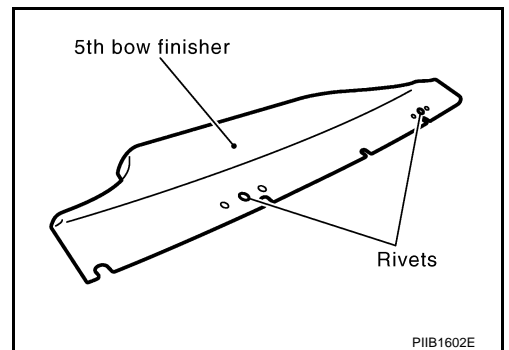

A
B
C
D
E
F
G
H
RF
J
K
L
M

SOFT TOP

5. Replace retainers under 5th bow finisher with a new part.

- Put new retainers under 5th bow finisher with rivet.
- Apply nonwoven fabric to retainer lower edge.

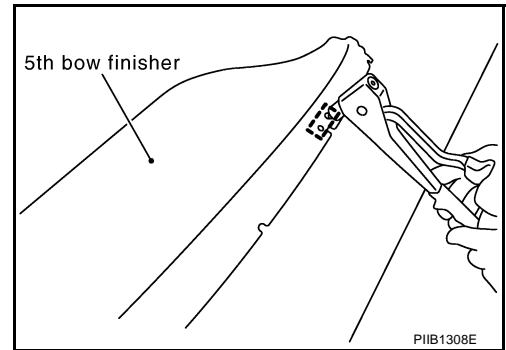

6. Remove remains of soft top cover mounting rivet from 5th bow and C link.

NOTE:

- Put a steel plate between a rivet and harnesses on 5th bow for harness protection, when removing the remaining rivets by drill.

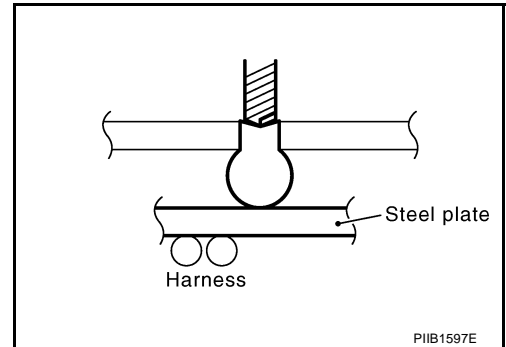

CAUTION:

Take out the remains of rivets completely from 5th bow, other wise the remains cause noise.

NOTE:

- Blow remains of rivet toward both ends of 5th bow with compressed air if they are in 5th bow.

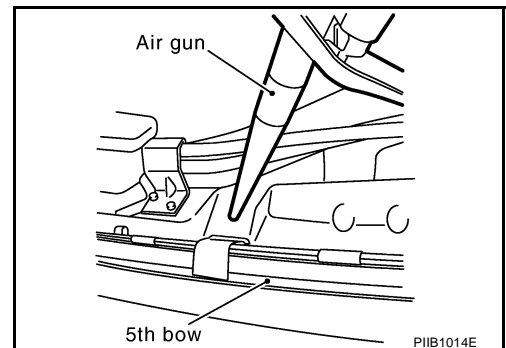

- Remove the remains drawn to both ends by the air blow from the gap.

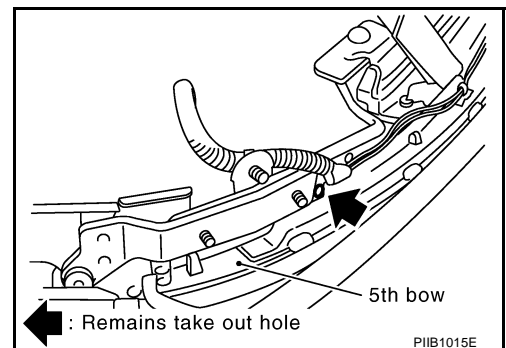

SOFT TOP

7. Install 5th bow finisher to 5th bow.

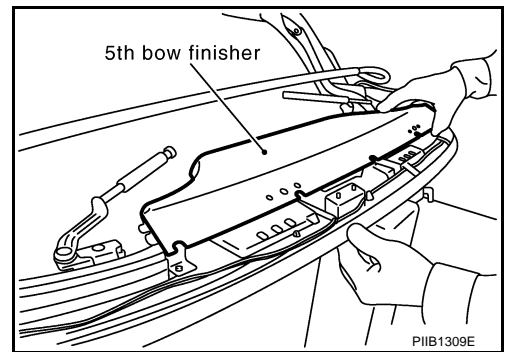

8. Install 5th bow side finisher (RH/LH) to 5th bow.

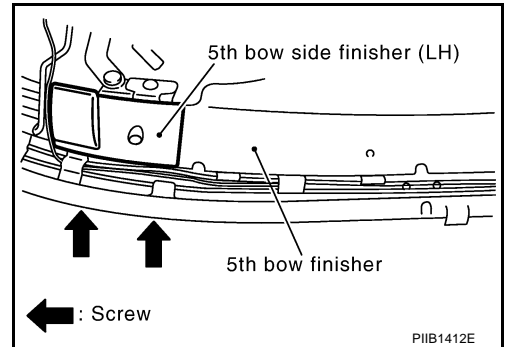

9. Install new pads and fabric tapes.

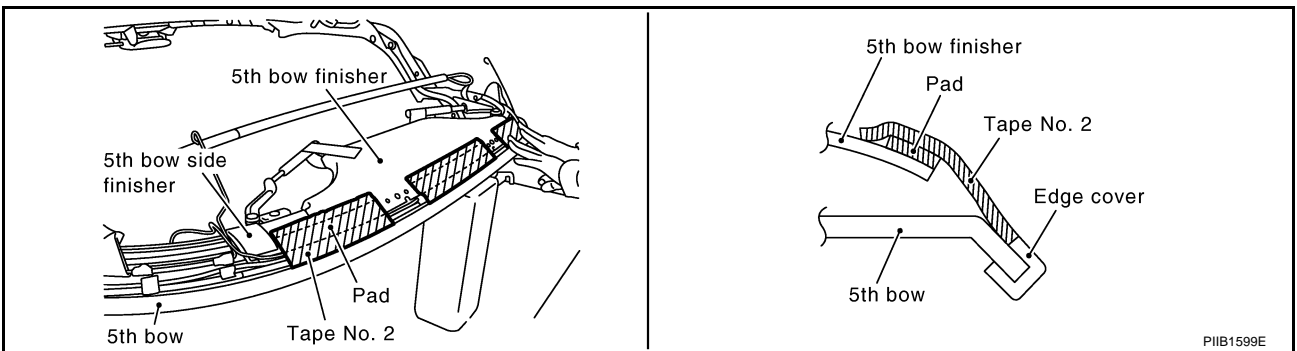

10. Secure 5th bow finisher harness with new nonwoven fabric if necessary.

Installation

1. Apply double faced adhesive tape for frame.

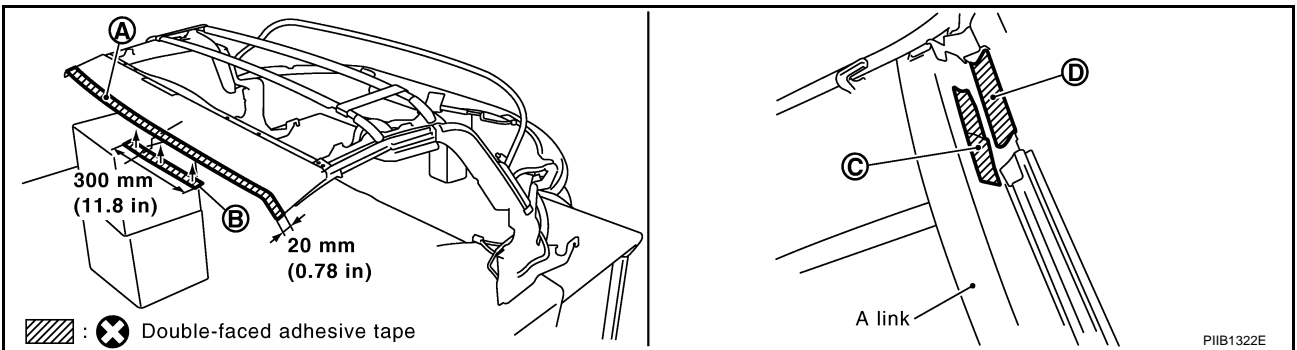

- A: Upper side of 1st bow
- B: Under side of 1st bow
- C: Outer side of A link (between grommets)
- D: Outer and under side of 1st bow edge

2. Put soft top cover on frame.

A
B
C
D
E
F
G
H
RF
J
K
L
M

SOFT TOP

3. Put glass stays and defogger harnesses into sleeves on both side of rear window.
 - Out side bag is for glass stay.
 - Inside bag is for harness.
4. Hook soft top cover inner fabric edge to 3rd bow retainer and press retainer to hold securely.

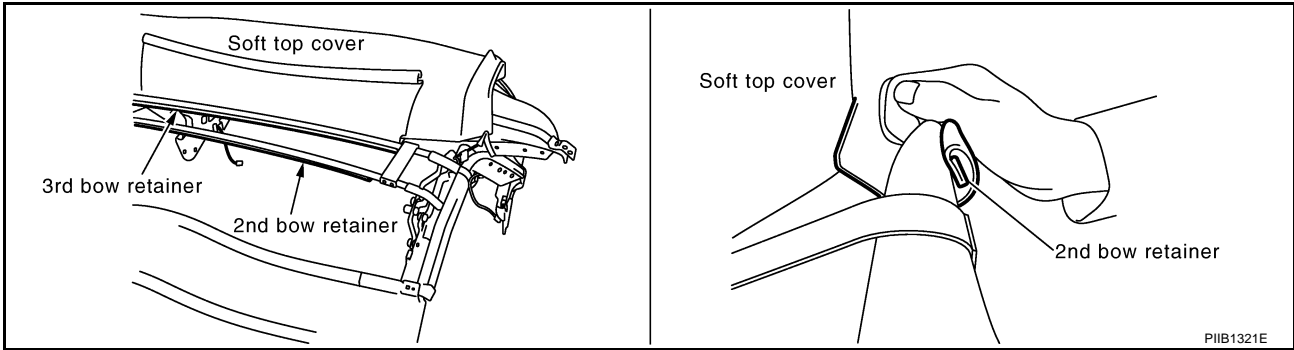

5. Hook soft top cover inner fabric edge to 2nd bow retainer and press retainer to hold securely.
6. Wrap soft top cover around 4th bow and fix soft top cover by velcro fastener.

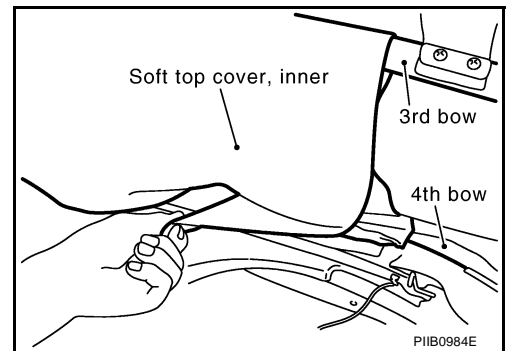

7. Insert soft top cover wire to A link.

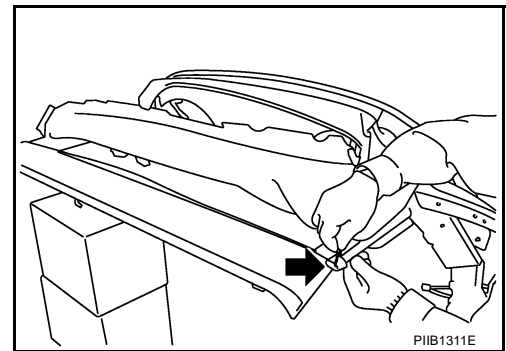

8. Tighten soft top cover wire rear bracket to C link with screw.
(Face tension wire outside.)

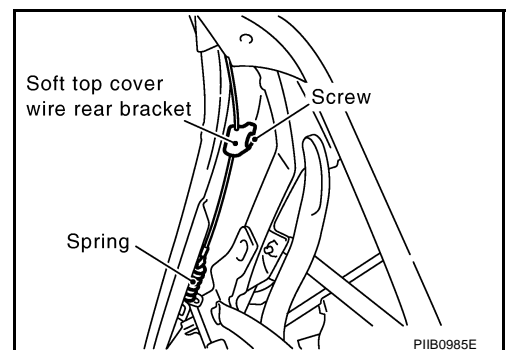

9. Hook soft top cover wire spring on C link and bend the hook of wire spring to prevent unhooking the hook.

SOFT TOP

10. Put soft top cover on 1st bow.

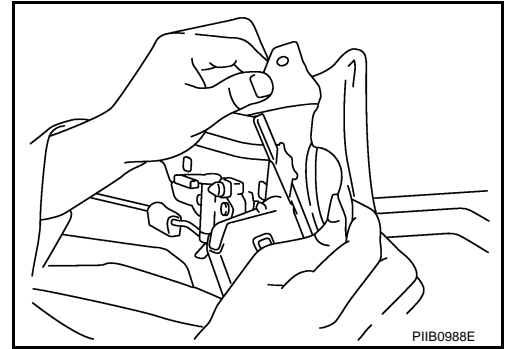

11. Align soft top cover hole and grommet hole at the 1st bow.

12. Tighten screws on 1st bow with front center retainer.

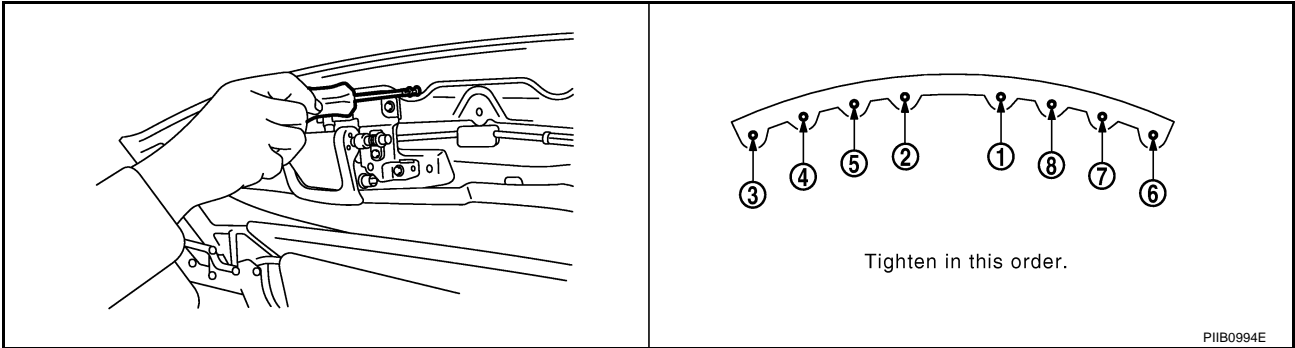

13. Apply EPT seal to A link installation position.

CAUTION:
Install EPT seal to the original position.

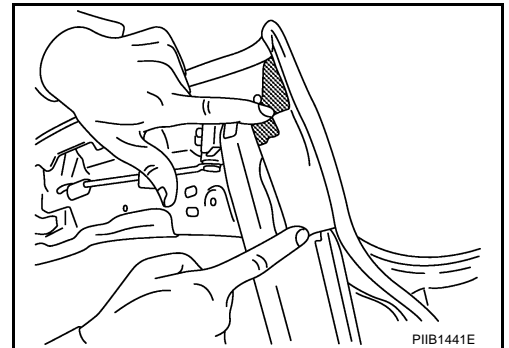

14. Put soft top cover on C link lower.

NOTE:

- Make sure that vinyl tube is on C link bottom end bracket.
- Be careful not to pull soft top cover with too much tension.

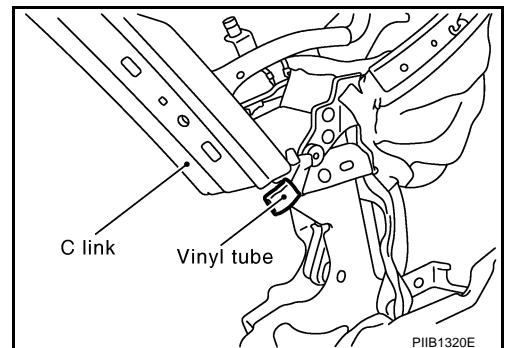

A
B
C
D
E
F
G
H
RF
J
K
L
M

SOFT TOP

15. Open 5th bow then secure soft top cover to 5th bow finisher upper surface with rivet.

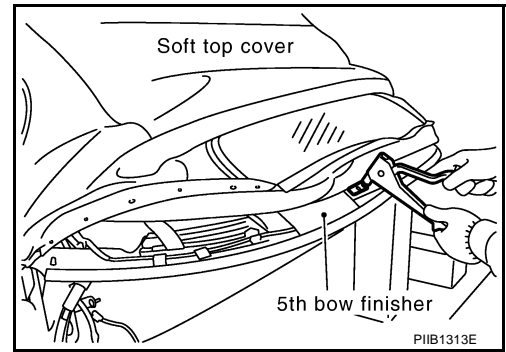

16. Close 5th bow then wrap soft top cover around 5th bow.
17. Secure soft top cover to 5th bow with rivet.

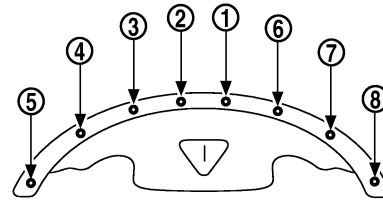
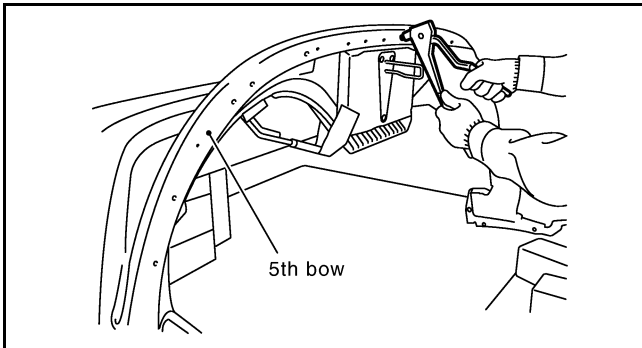

PIIB1003E

18. Secure soft top cover to C link with rivet.

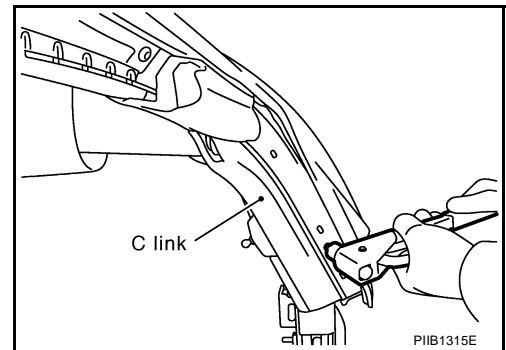

19. Align screw hole on soft top cover and the bottom of C link, and then tighten with screw.

NOTE:

- During tighten up the screw, insert a thin metal rod such as a nail [diameter: 4mm (0.16in)] to a clip hole near the screw to align holes of soft top cloth and its backing plastic plate, and C link frame.
- Tighten screw while holding soft top at certain angle for easy screw installation.

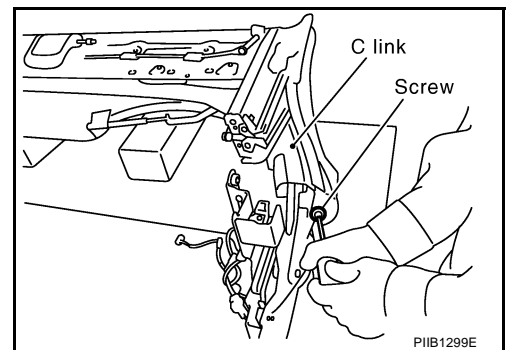

SOFT TOP

20. Close 5th bow then install 5th bow retainer with screws.

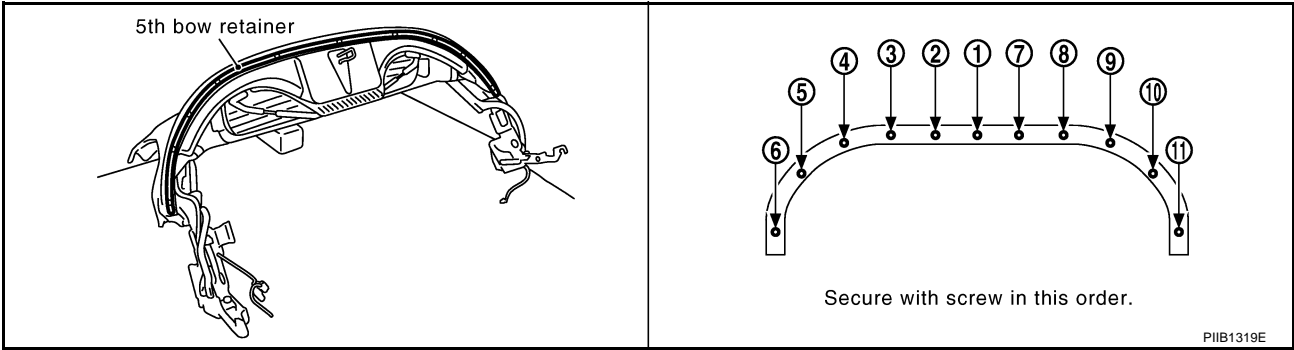

CAUTION:

Apply it to the original position.

NOTE:

During tighten up the screw, insert a thin metal rod such as a nail [diameter: 4mm (0.16in)] to a clip hole near the each end of 5th bow retainer to align holes of the retainer, soft top cloth and its backing plastic plate, and 5th bow.

21. Install C link retainer with screws.

NOTE:

Align matching marks on the retainer to screw heads, when installing the retainer.

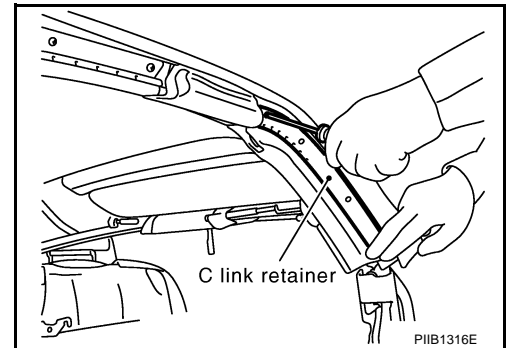

22. Apply seal to C link lower installation position.

CAUTION:

Make sure not to cover clip hole and screw head.

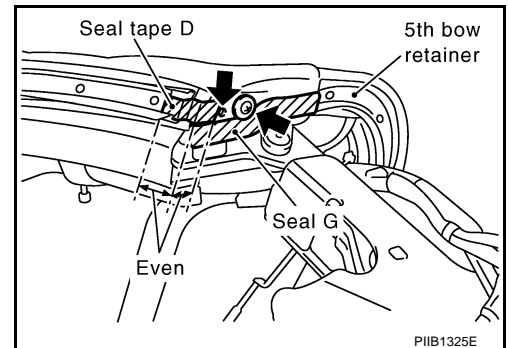

23. Install A link retainer with screws.

NOTE:

Align matching marks on the retainer to screw heads, when installing the retainer.

24. Apply seal E to A link installation position.

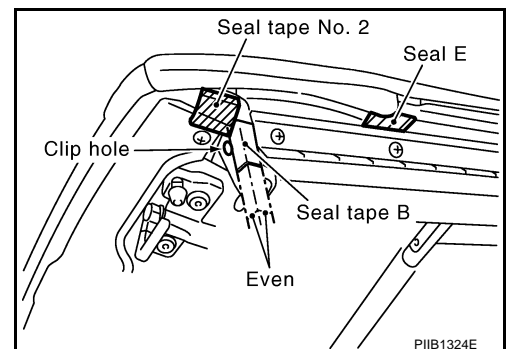

A
B
C
D
E
F
G
H
RF
J
K
L
M

SOFT TOP

25. Recheck seals for A link and C link.

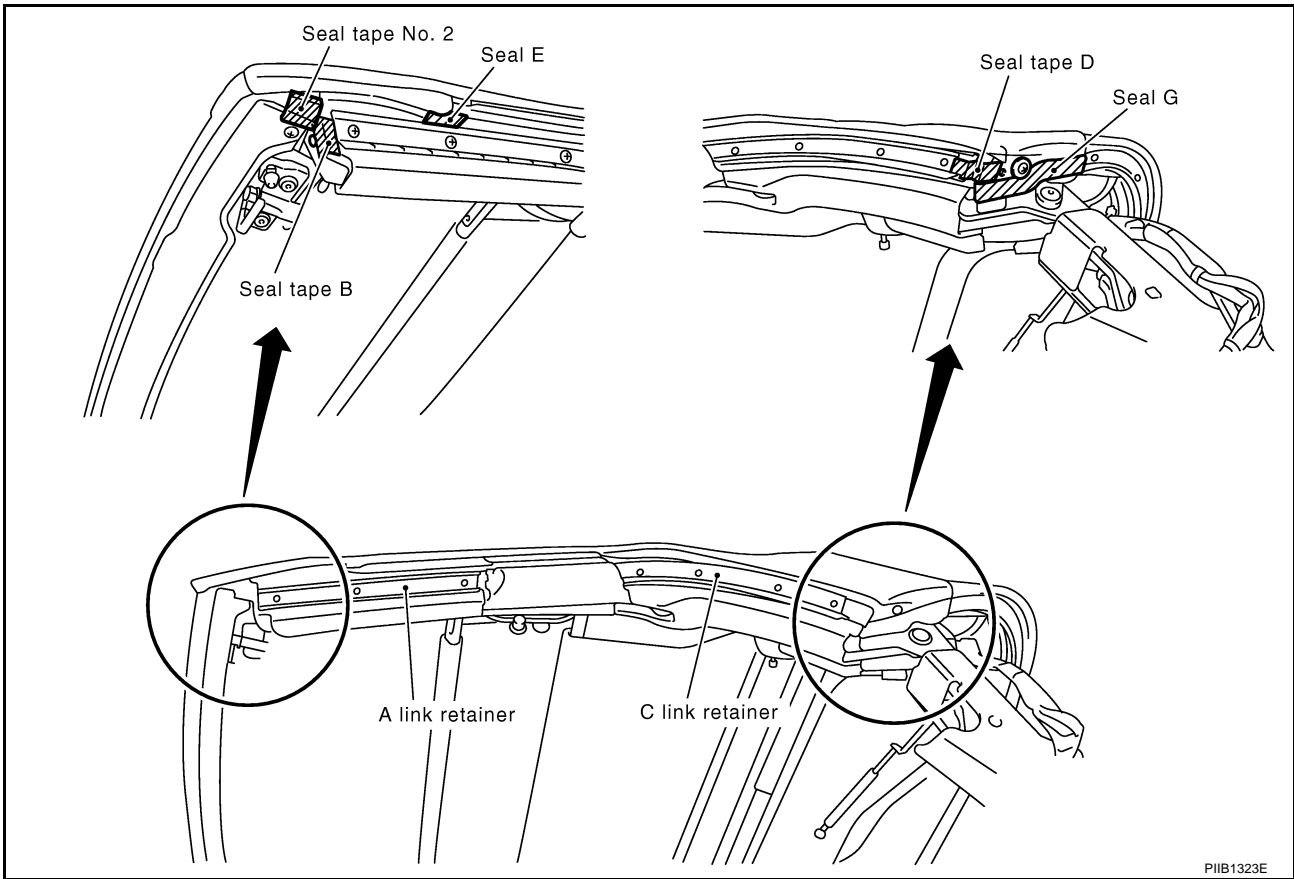

26. Install C link and 5th bow weatherstrip to 5th bow and C link.

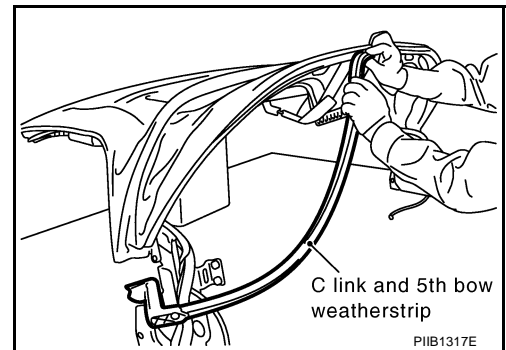

27. Remove protection tape on the limit switch.

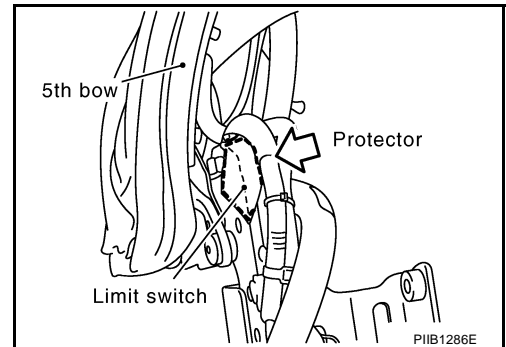

SOFT TOP

28. Install A link weatherstrip.

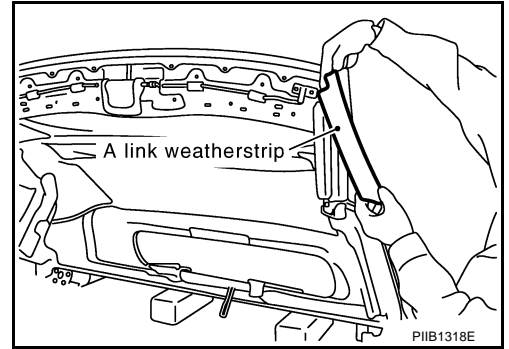

29. Install front lock finisher and welt after closing soft top.

30. Connect defogger harnesses at rear window.

31. Install 5th bow operating strut rods (RH/LH).

32. Install roof actuator (RH/LH). Refer to [RF-107, "Removal and Installation of Roof Actuator"](#) .

33. Install soft top assembly to vehicle. Refer to [RF-87, "Removal and Installation of Soft Top Assembly"](#) .

34. Check soft top open/close operation.

35. Check door glass contact. Refer to [GW-51, "FITTING INSPECTION"](#) .

36. Check for water leakage. Refer to [RF-115, "Repairing Method for Water Leakage Around Doors"](#) .

NOTE:

If there are wrinkles on the soft top cover, use a hair dryer to warm up the wrinkled area. Apply warm air from the hair dryer keeping the distance by 150 - 200 mm (5.9 - 7.8 in) and move the dryer to gently warm up soft top cover, for about 5 - 10 minutes until the wrinkle seems to be gone. Not to heat up soft top cover to much.

A

B

C

D

E

F

G

H

RF

J

K

L

M

SOFT TOP

AI/S0065B

Removal and Installation of Switches

REMOVAL

1. Uninstall soft top assembly from the vehicle. Remove roof actuator (RH/LH) from the soft top.
2. Remove harness tie wrap band at the left side of the soft top.
3. Remove limit switches with plate rail RR bracket by removing bolt.

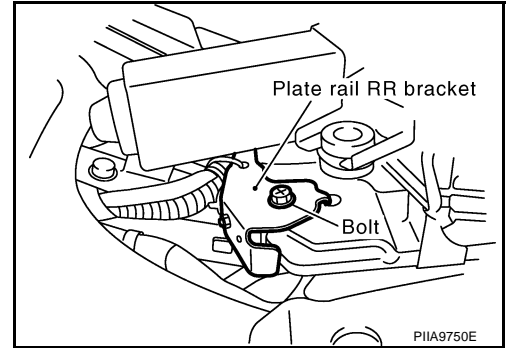

4. Remove limit switches with soft top switch bracket 1 by removing bolt.

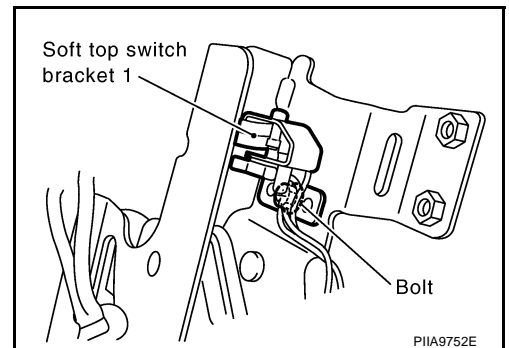

5. Remove limit switches with soft top switch bracket 2 by removing bolt.

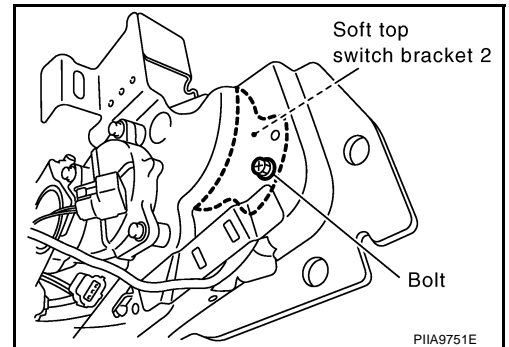

INSTALLATION

Install in the reverse order of removal.

NOTE:

Wire harnesses correctly to avoid following situation.

- Pinching harnesses by frame
- Tangling harnesses by frame and links
- Pulling harnesses between fixing point by harness clips.

SOFT TOP

Removal and Installation of Roof Actuator

AIS0065C

REMOVAL

1. Remove soft top assembly. Refer to [RF-87, "Removal and Installation of Soft Top Assembly"](#) .
2. Remove nuts and then remove roof actuator (RH/LH).

NOTE:

If removal is difficult, rotate motor axis to remove them.

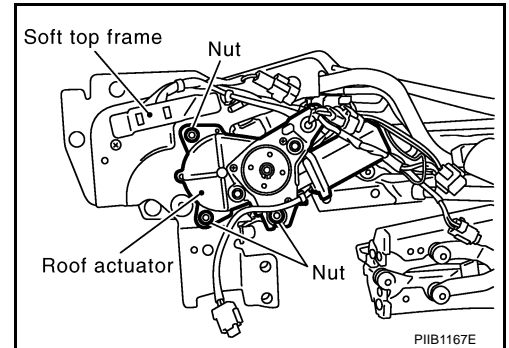

3. Disconnect soft top actuator harness connector.

INSTALLATION

Install in the reverse order of removal.

Removal and Installation of 5th Bow Drive Unit

AIS0065D

REMOVAL

1. Uninstall soft top assembly from the vehicle.
2. Remove roof actuator (RH/LH) from the soft top.

NOTE:

If removal is difficult, rotate motor axis to remove them.

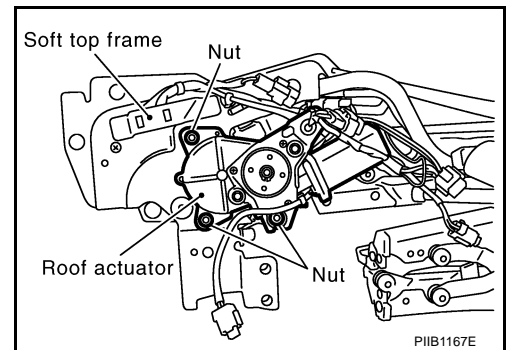

3. Disconnect 5th bow operating rod (RH/LH) at the frame side by pulling out the holder.

NOTE:

This step will make the 5th bow up and down motion easier.

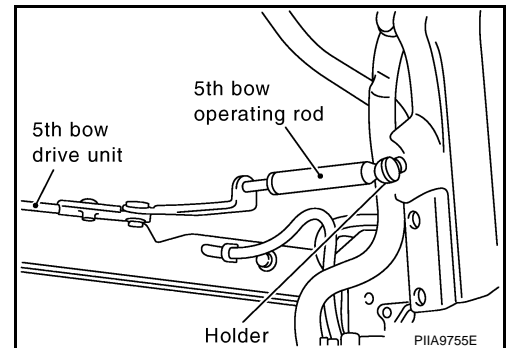

4. Make sure that the limit switch contact around the rotation axis of the 5th bow on the left side of soft top is protected with tape.
5. Open the soft top manually, and put a stand under the 1st bow. Then fix the soft top not to move during this procedure.

NOTE:

Put a waste cloth between the front lock and the stand not to make any scratches to the soft top.

6. Remove the C link and 5th bow weatherstrip.

SOFT TOP

7. Remove the soft top cover retainer (5th bow retainer) from 5th bow by taking out screws.

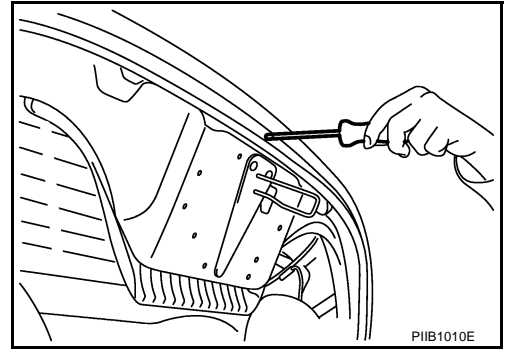

8. Drilling rivets attaching the soft top cover to 5th bow, then pull up the soft top cover bottom edge.

NOTE:

Use 4 mm (0.16 in) diameter drill bit to remove the rivet head. When drilling rivets, be careful not to damage the soft top cover.

9. Drilling rivets with retainers attaching with tags from the soft top cover, 5th bow finisher and the 5th bow.

NOTE:

Use 4 mm (0.16 in) diameter drill bit to remove the rivet head. The soft top cover is separated from 5th bow.

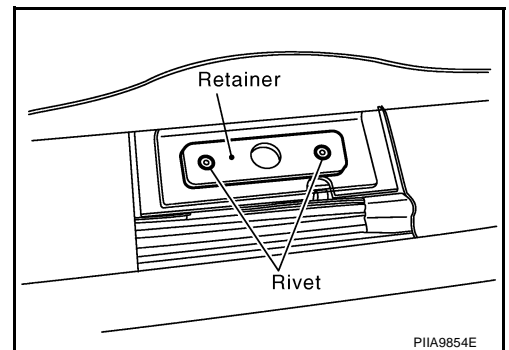

10. Drilling rivets under retainers by using 4 mm (0.16 in) diameter drill bit.

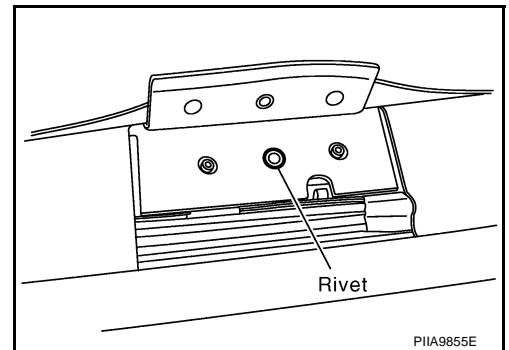

11. Remove pads from 5th bow finisher.

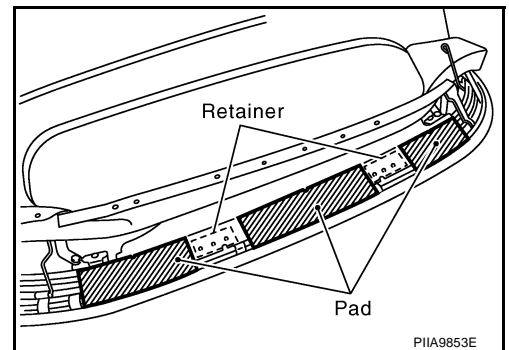

SOFT TOP

12. Roll the soft top cover bottom edge up, and disconnect defogger harness connector from the rear window glass.
13. Pull out glass stays from sleeves on each side of the rear window glass.

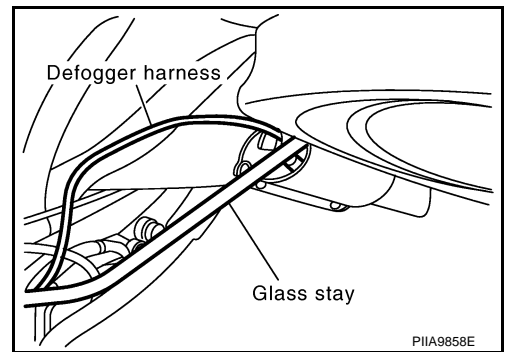

14. Remove 5th bow side finisher (RH/LH) by removing screws.

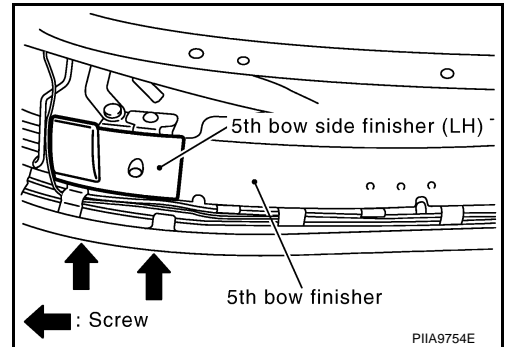

15. Remove 5th bow finisher by pulling the finisher up.

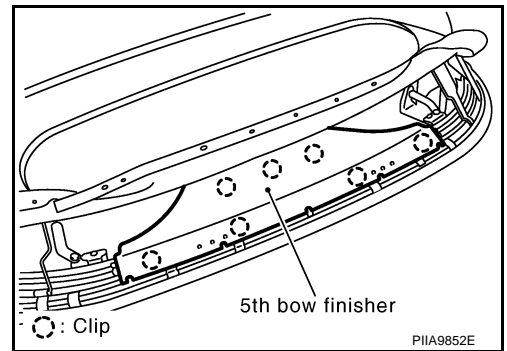

16. Remove glass stays from 5th bow by removing screws from the bottom of the 5th bow.

NOTE:

- When removing glass stays, support 5th bow to avoid a bend of glass stay. This bend may happen by the weight of the 5th bow and the tensile force of the tether from the soft top cover.
- Be careful not to damage the 5th bow nor to be hurt by the falling 5th bow, because the 5th bow is heavy and moves freely after removing glass stays.

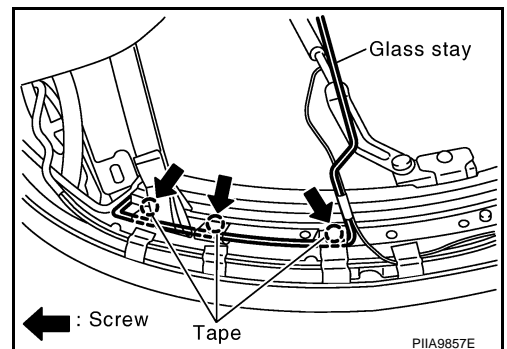

17. Disconnect 5th bow drive unit harness connector.

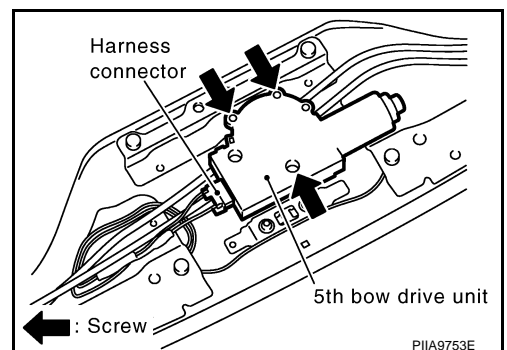

A
B
C
D
E
F
G
H
RF
J
K
L
M

SOFT TOP

18. Remove 5th bow drive unit and rails together from 5th bow by removing screws.

NOTE:

- After removing drive unit and rails, not to pull rails. Otherwise, the wire in the rail may be damaged.
- The screws are not reusable.

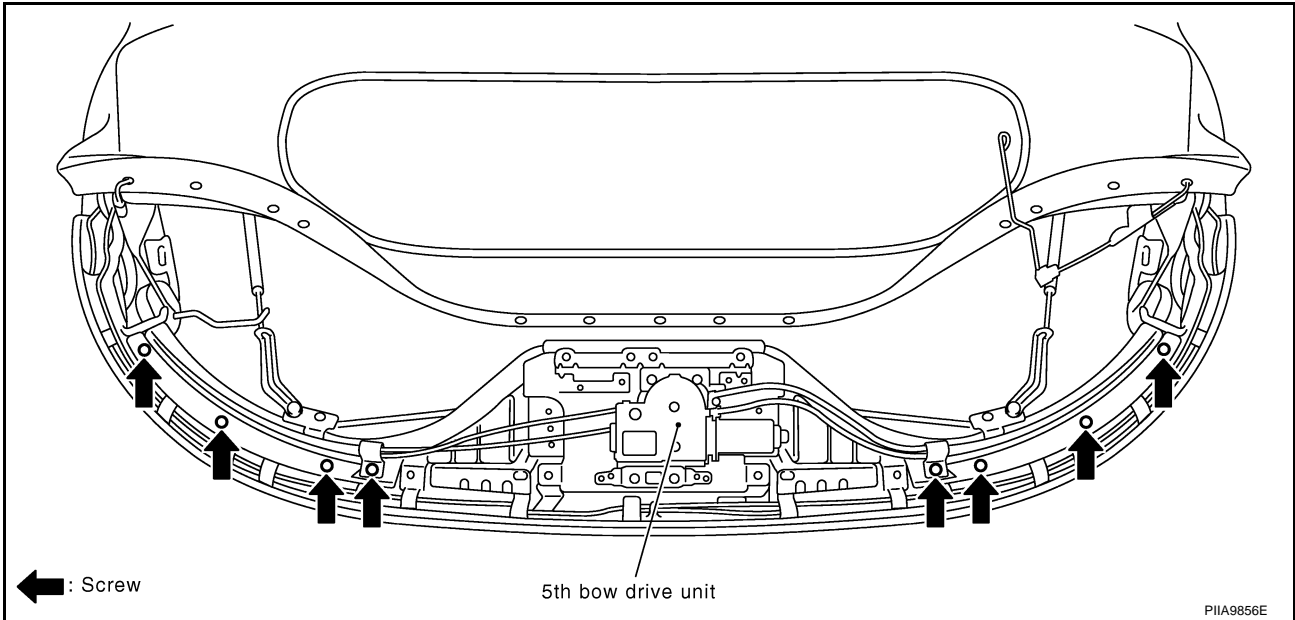

INSTALLATION

Preparation Work

1. Blow remains of rivet toward both ends of 5th bow with compressed air if they are entering into 5th bow.

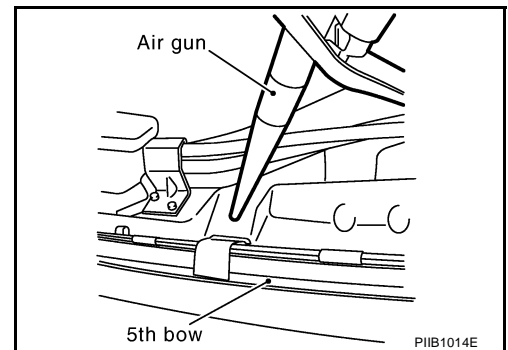

2. Remove the remains drawn to both ends by the air blow from the gap.

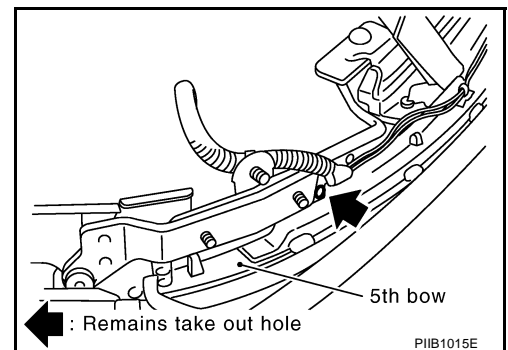

SOFT TOP

3. For fixing harness to 5th bow and Soft top frame, see next figure.

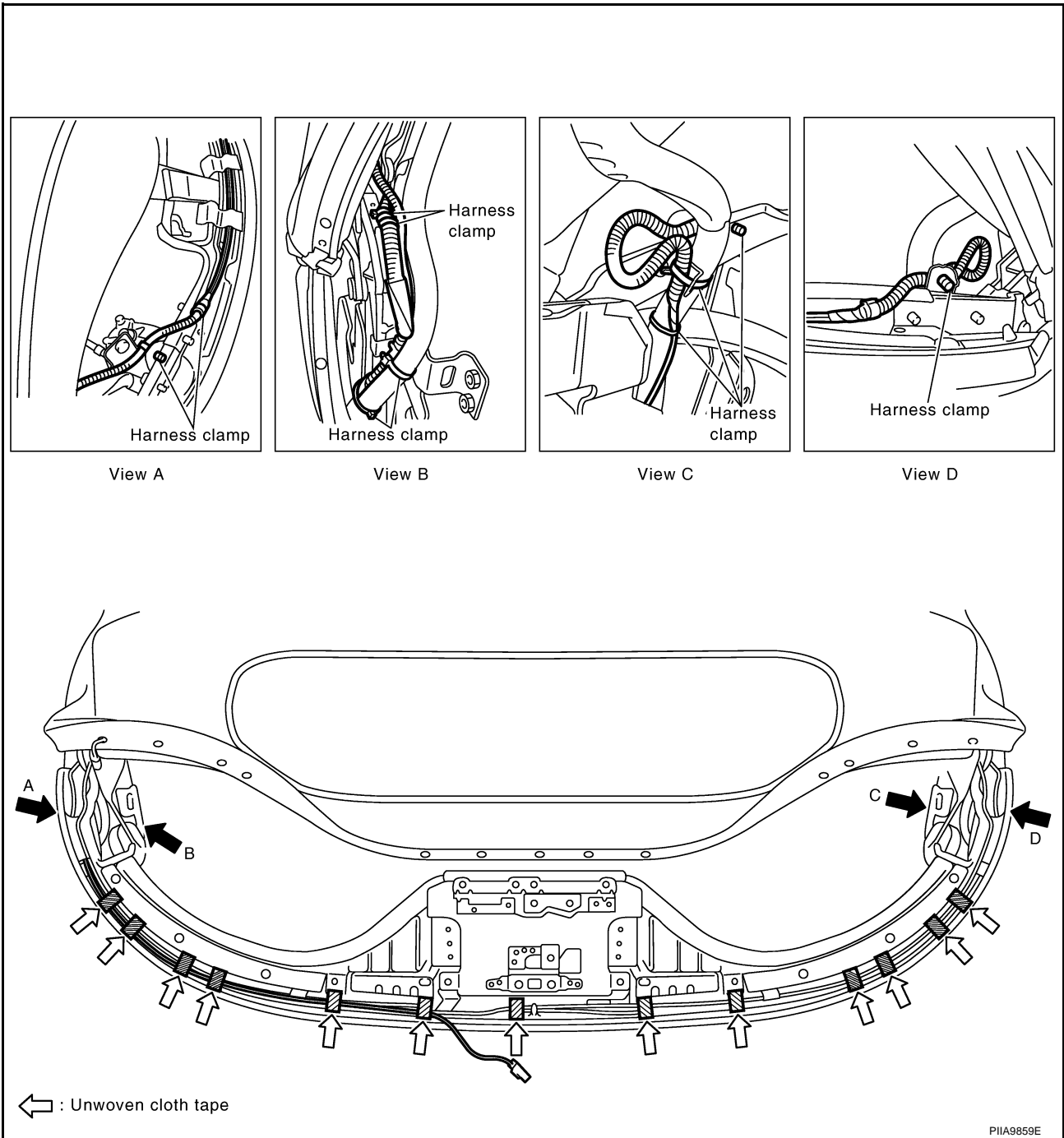

A
B
C
D
E
F
G
H
RF
J
K
L
M

SOFT TOP

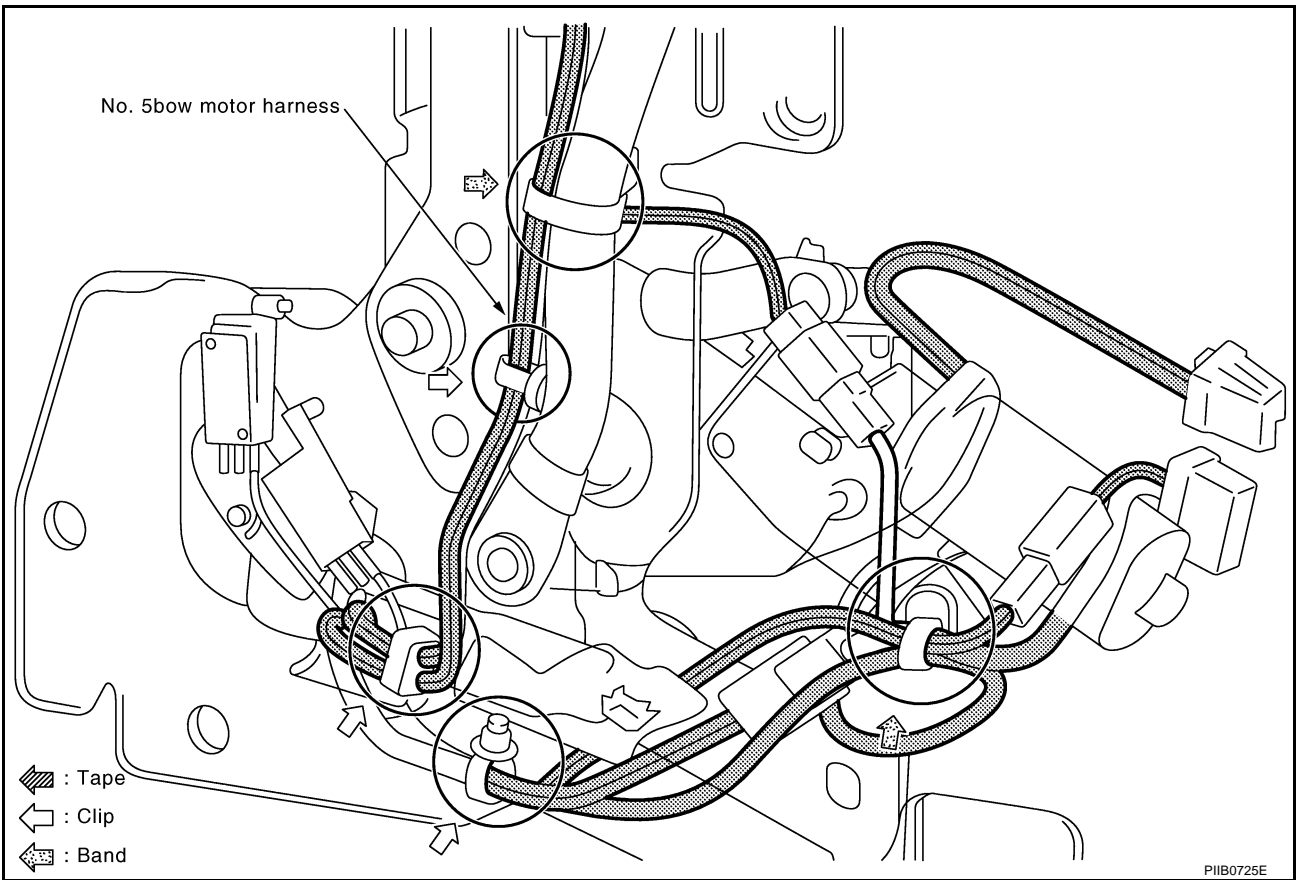
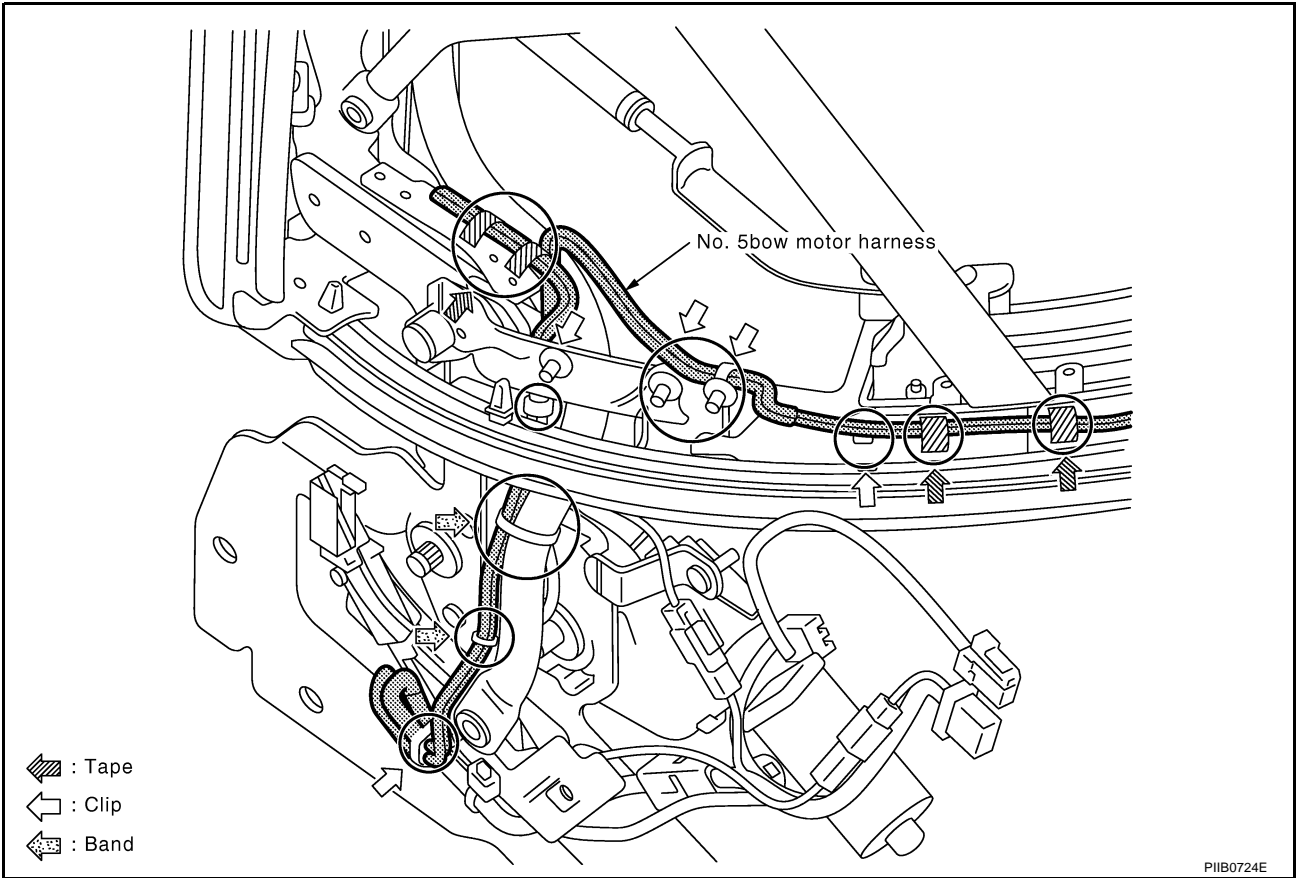

SOFT TOP

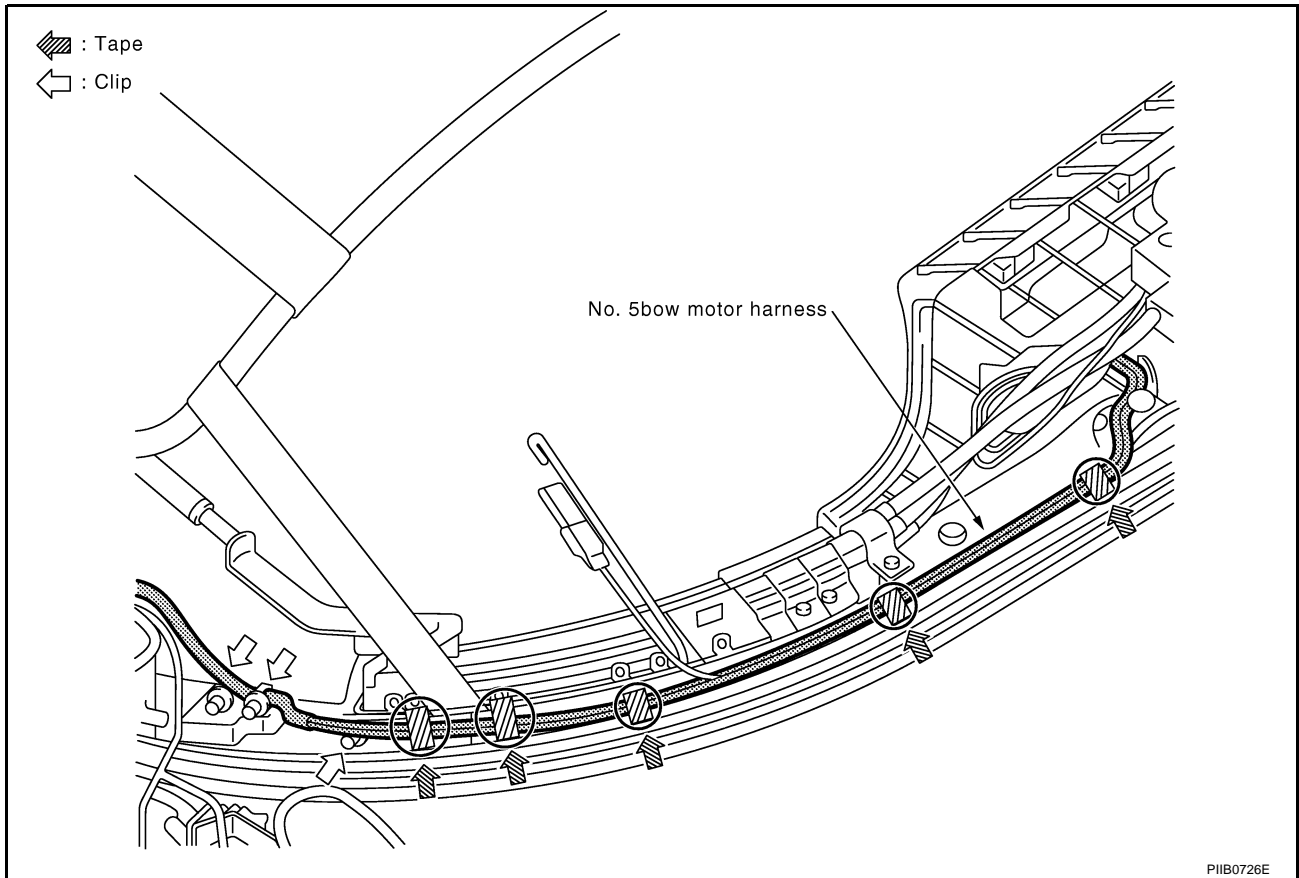

4. Replace rivet retainer on back of 5th bow finisher with a new one.
5. Secure 5th bow finisher with rivet, and then apply nonwoven fabric.
6. Install 5th bow finisher and 5th bow finisher (RH/LH).
7. Apply pad on 5th bow finisher.

NOTE:

Apply pad to the original position.

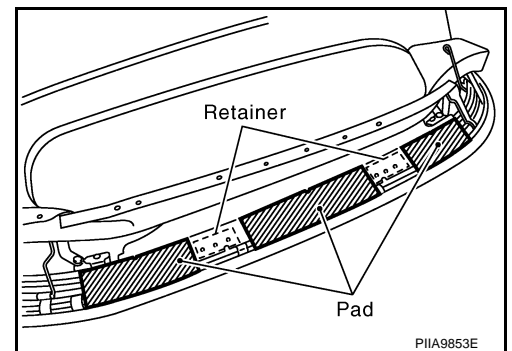

Installation

Install in the reverse order of removal.

A
B
C
D
E
F
G
H
RF
J
K
L
M

SOFT TOP

AIS0065E

Removal and Installation of Front Lock REMOVAL

1. Remove welt and front finisher.
2. Remove bolts, and then remove front lock rod.

CAUTION:

Do not remove front lock hook, center bolts.

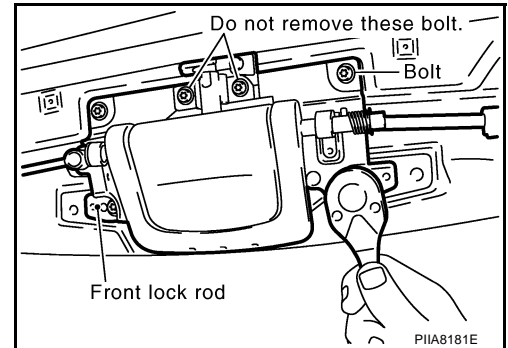

3. Remove bolts, and then remove front lock striker, LH, center, and RH.

NOTE:

Paint matching marks for front lock assembly to check location for installation.

INSTALLATION

Install in the reverse order of removal.

- Always adjust before installation. Refer to [RF-114, "INSPECTION AND ADJUSTMENT"](#).

INSPECTION AND ADJUSTMENT

1. Apply super-check spray on a contact surface of 3 hooks which may touch with rods on the body. Fully close soft top, and then engage front lock.
2. Open soft top, and then make sure that the part, from which iron material is visible by peeling off super-check mark, exceeds "L" line.

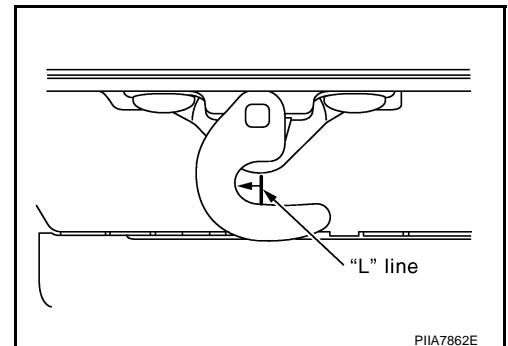

3. Adjust hook contact length by adjusting front lock rod length using front lock rod adjust bolt if "L" line is not exceeded in front lock hook, RH and LH.

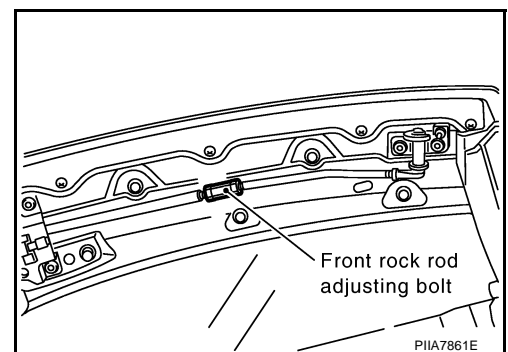

4. There is a part malfunction, if "L" line is not exceeded in front lock center hook. Replace front lock assembly.
5. Make sure that the super check mark exceeds the "L" line, and then measure the fully closed operating force while contacting push-pull gauge to the handle. Make sure that the operating force is 68.6 N (7 kg, 15.4 lb) or less, and then install it.

NOTE:

- Replace front lock assembly if the operating force is over the specified value.

SOFT TOP

- Make sure that operating force when replacing front weatherstrip, center weatherstrip, and rear weatherstrip is 107.8 N (11 kg, 24.2 lb) or less.

Repairing Method for Water Leakage Around Doors

AIS0065F

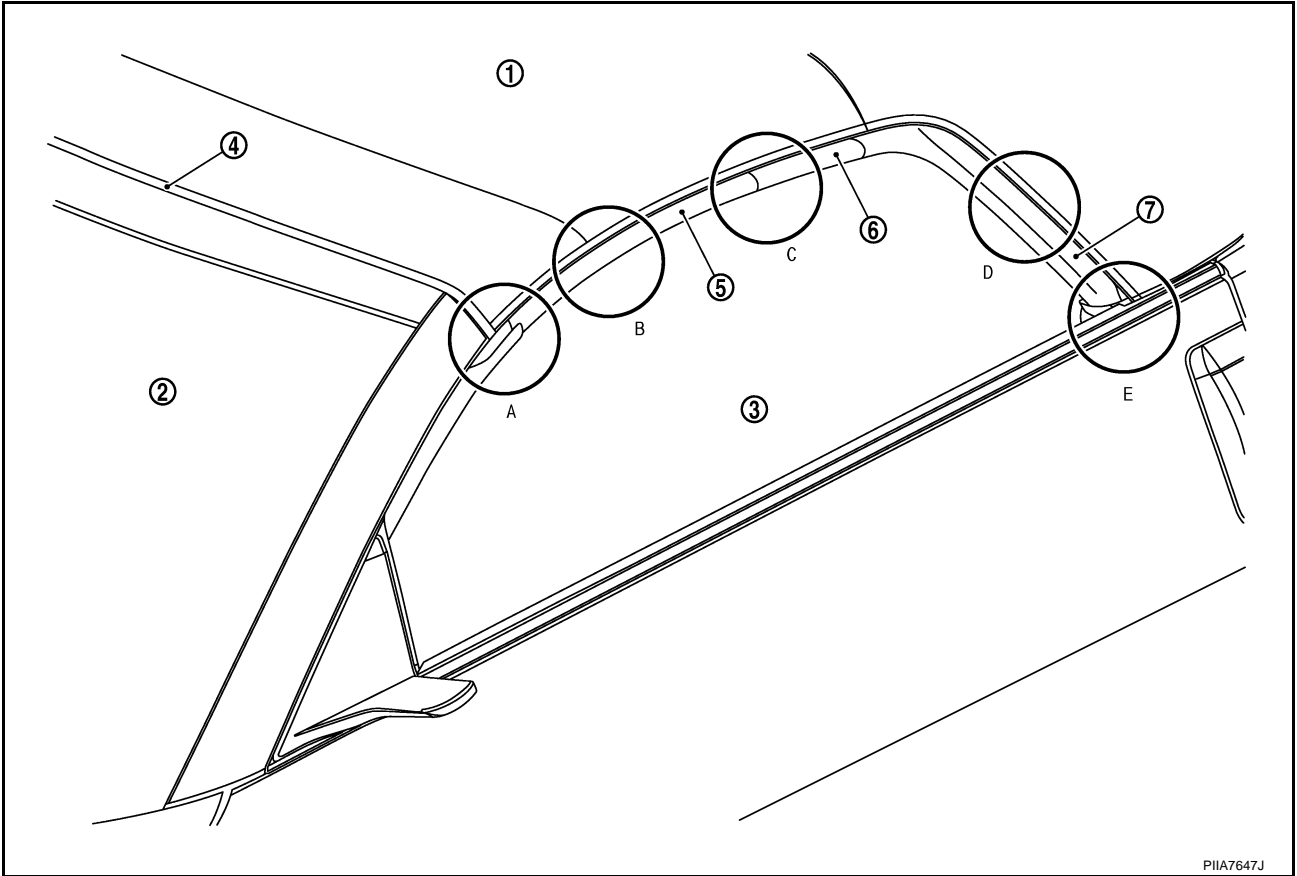

- | | | |
|------------------------------------|------------------------|------------------------|
| 1. Soft top assembly | 2. Windshield glass | 3. Door glass |
| 4. Glass run assembly | 5. A link weatherstrip | 6. B link weatherstrip |
| 7. C link and 5th bow weatherstrip | | |

WATER LEAKAGE FROM A

Water may be entering passenger room through back of front pillar.
Cause: Butyl tape on back of glass run assembly may be separating from roof panel.

Repair Procedure 1

Apply butyl tape on back of glass run assembly again, and correct installing position.

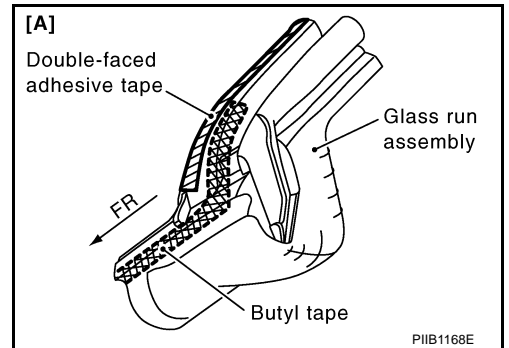

Water may be entering through connection between front pillar and front edge of soft top.
Cause: There may be a gap between glass run assembly and weatherstrip of soft top.

SOFT TOP

Repair Procedure 2

Replace glass run assembly with a new one to eliminate the gap between glass run assembly and weatherstrip.

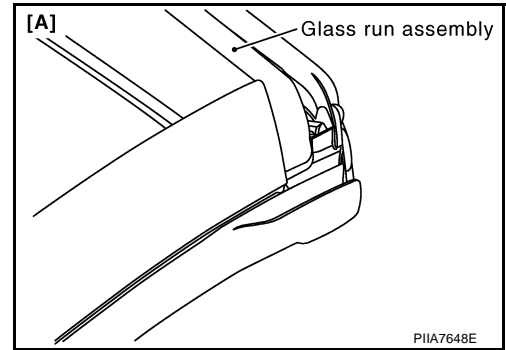

WATER LEAKAGE FROM B

Water may be entering through door glass upper inside edge.

Cause: There may be poor contact between A link weatherstrip of soft top and door glass.

Repair Procedure 3

- Adjust door glass position frontward/backward or upward/downward against soft top assembly.
- Adjust door glass tilt contact by rotating adjusting bolt on regulator lower edge.

CAUTION:

Soft top assembly position may be incorrect when glass upper position is low even if door glass adjustment is performed. Perform soft top assembly adjustment, if necessary. Refer to [GW-49, "FRONT DOOR GLASS AND REGULATOR"](#).

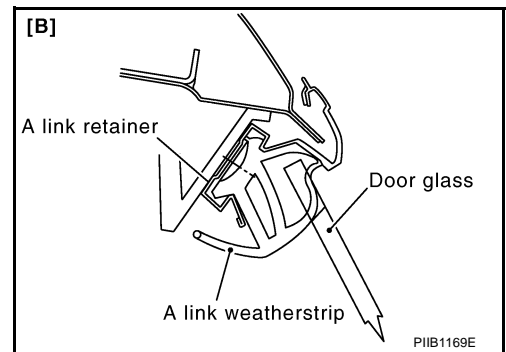

Adjust door glass tilt contact by rotating adjusting bolt on regulator lower edge.

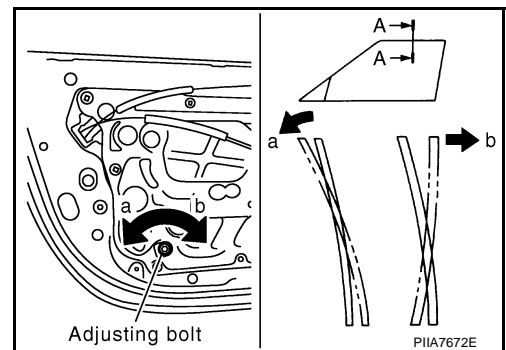

WATER LEAKAGE FROM C

Water may be entering through a joint between soft top weatherstrips.

Cause: There may be a step or a gap at the weatherstrips joint.

Repair Procedure 4

- Replace weatherstrip with a new one.
- If the step or the gap is not eliminated after replacing weatherstrip, then perform the following procedure.

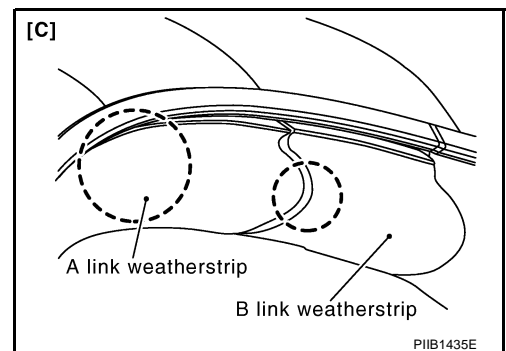

SOFT TOP

Repair Procedure 5

- Loosen retainer screws.
- Make fine upward/downward position adjustments to the B link retainer.
(Move the B link retainer of a protruded weatherstrip downward for the adjustment.)
- Insert approximately 0.5 mm (0.02 in) washer into the back of the subsiding weatherstrip retainer, if the step is not eliminated after adjustment.

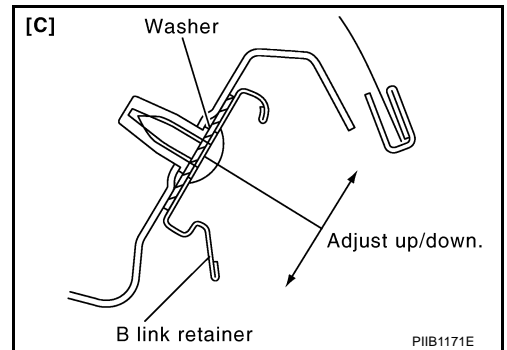
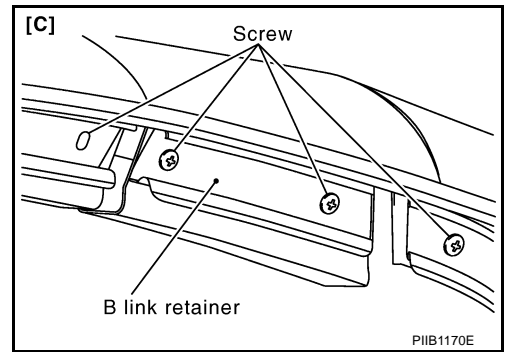

WATER LEAKAGE FROM D

Water may be entering through inside door glass rear.

Cause: There may be poor contact between Clink and 5th bow weatherstrip of soft top and door glass.

Repair Procedure 6

- Adjust door glass position frontward/backward or upward/downward against soft top.
- Adjust door glass tilt contact by rotating adjusting bolt on regulator lower edge.

CAUTION:

Soft top assembly position may be incorrect in the case of glass upper position is low even if door glass adjustment is performed. Perform soft top assembly adjustment if necessary. Refer to [GW-49, "FRONT DOOR GLASS AND REGULATOR"](#).

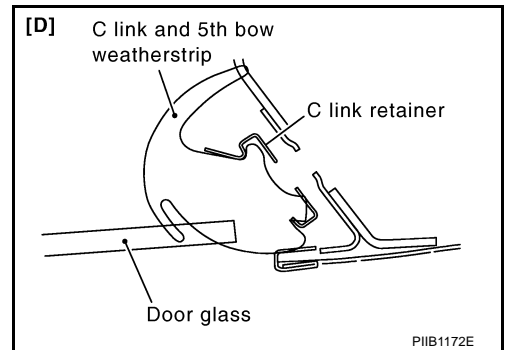

WATER LEAKAGE FROM E

Water may be entering passenger room through weatherstrip joint.

Cause: There may be a step or a gap between C link and 5th bow weatherstrip side and body side of weatherstrip.

Repair Procedure 7

- Remove C link weatherstrip.
- Remove C link retainer.

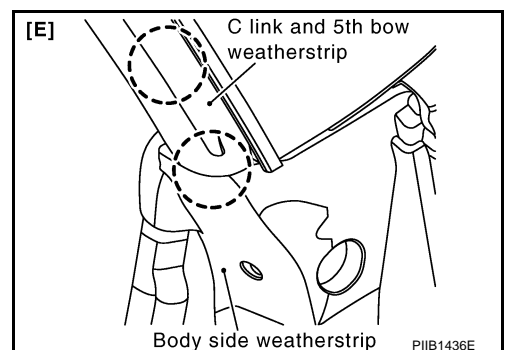

SOFT TOP

- Apply approximately 5 mm (0.2 in) thick EPT seal to retainer back surface.

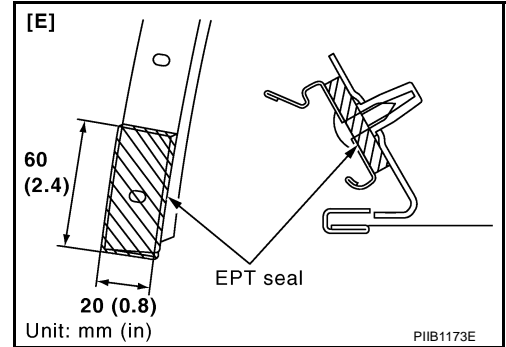

WATER LEAKAGE TEST

Visually check for water leakage after repairing.

1. 2 workers are required. One worker checks inside the vehicle, and the other one washes with water.
2. Use 13 mm (0.51 in) diameter hose. Adjust water pressure by following method. Hold the hose horizontally, and release water at 1000 mm (39.37 in) height from ground. Adjust the distance, between the ground point just below the hose and the water dropping point, to reach 700 mm (27.56 in). (See the figure.)
3. Keeping the distance between the hose and the testing area by 100 mm (3.94 in), apply water along the area 3 times. During applying water, move the hose by 100 mm (3.94 in)/sec speed.

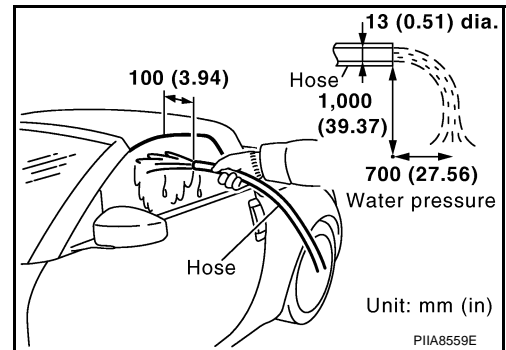

4. Visually check for water leakage.

SOFT TOP

Correspondence in Emergency

AIS0065G

If the soft top cannot be operated electrically in the event of a discharged battery or any other system malfunction, the soft top needs to be closed manually or opened manually according to the following procedures.

MANUAL OPERATION (SOFT TOP FULLY OPEN ⇒ FULLY CLOSE)

1. Open The Trunk Lid

- Open the lid behind the passenger's seat (rear floor box).
- Remove cap of the emergency cable.
- Pull the emergency cable upper surface in the box.
- Open trunk lid.

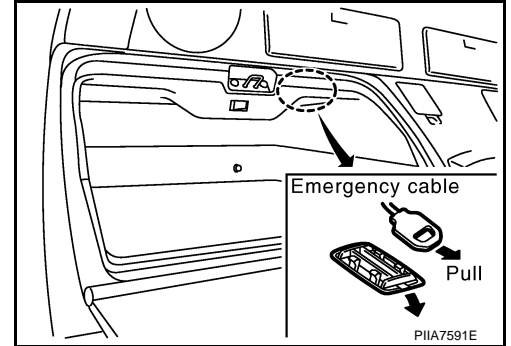

2. Open The Storage Lid

- Remove floorboard inside of the trunk.
- Disconnect the storage lid motor harness connector upperward, which is located at the right hand side of the trunk.
- Pull down the storage lid lock release cable (right and left sides in the trunk).
- Confirm a clicking sound of lock release.
- Pull up the storage lid from the right and left sides of vehicle (two people are required).

CAUTION:

The storage lid is extremely heavy. Pulling it up should be done by two people. Use Hex-wrench to rotate the axis of the gear, when the lid does not move.

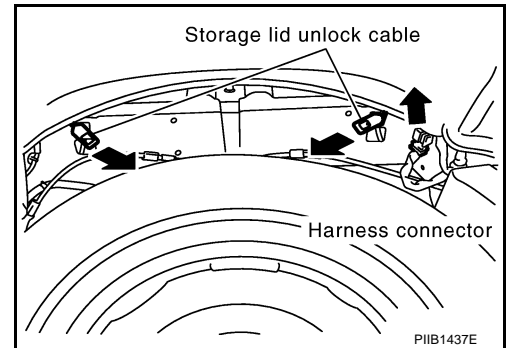

3. Close The Soft Top

- Disconnect roof actuator harness connector right and left sides.

CAUTION:

2nd disconnect top of roof actuator harness connector right and first disconnect top of roof actuator harness connectors left sides.

- Pull up the soft top right and left sides of the vehicle slowly by hand (two people are required).
- Lock soft top front lock.

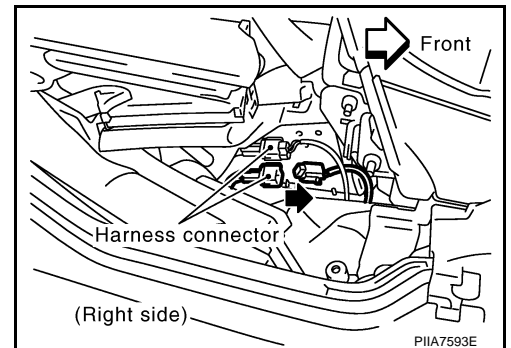

4. Close The Storage Lid

- Push down soft top to body panel.

A
B
C
D
E
F
G
H
RF
J
K
L
M

SOFT TOP

5. Lower The Soft Top 5th Bow

- Remove both operating rod of soft top 5th bow.

CAUTION:

Remove a holder of operating rod end.

Simultaneously hold soft top 5th bow by hand when removing the holder.

- Push in 5th bow to storage lid (do half lock).

CAUTION:

After closing the soft top manually according to the above procedures, have the soft top operation system checked and/or repaired by a NISSAN dealer as soon as possible.

Avoid leaving the vehicle outside for long periods or driving at high speed. As the rear of the soft top is not locked completely, this may allow wind and rain get into the vehicle.

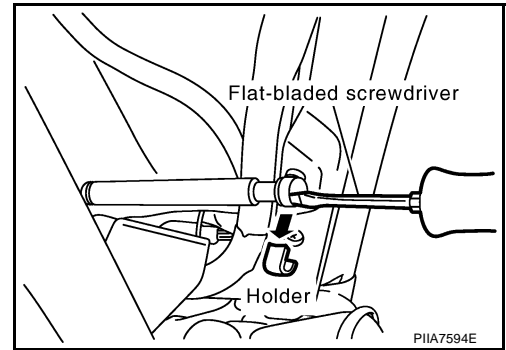

MANUAL OPERATION (SOFT TOP FULLY CLOSE ⇒ FULLY OPEN)

1. Remove The Luggage Floor Trim

- Remove the rear floor box and luggage floor finisher upper. Refer to [EI-32, "LUGGAGE FLOOR FINISHER UPPER"](#).

2. Cutting Storage Room Finisher

- Cut storage room finisher from seat side.

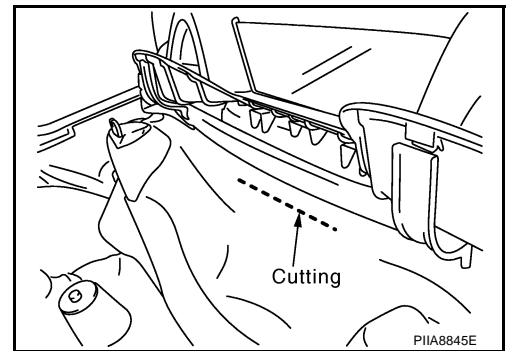

3. Unlock The Storage Lid

- Remove clip of inspection cover.

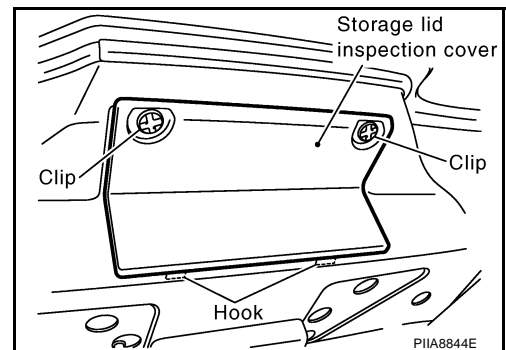

- Remove the storage lid inspection cover.
- Pull the unlock wire then unlock the soft top 5th bow.

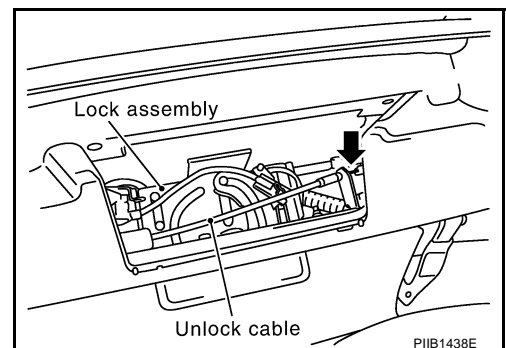

SOFT TOP

4. Open The Soft Top 5th Bow

- Remove both shock absorber of soft top 5th bow.
- Open the soft top 5th bow (approximate 90 degrees)

5. Open The Trunk Lid

- Pull the emergency cable.
- Open the trunk lid.

6. Open The Storage Lid

- Remove floorboard inside of the trunk.
- Disconnect the storage lid motor harness connector downward which is in the right hand side of the trunk.
- Pull down the storage lid lock release cable (right and left side of the trunk).
- Confirm a clicking sound of lock release.
- Pull up the storage lid from the right and left sides of vehicle (two people are required).

CAUTION:

The storage lid is extremely heavy. Pulling it up should be done by two people. Use Hex-wrench to rotate the axis of the gear, when storage lid does not move.

- Disconnect roof actuator harness connector right and left side (disconnect top of roof actuator harness connector right and left side)

7. Open The Soft Top

- Lower the soft top 5th bow.
- Unlock the front lock.
- Open the soft top right and left side of the vehicle slowly by hand (two person job).

8. Close The Storage Lid

NOTE:

If necessary.

9. Close The Trunk Lid

NOTE:

If necessary.

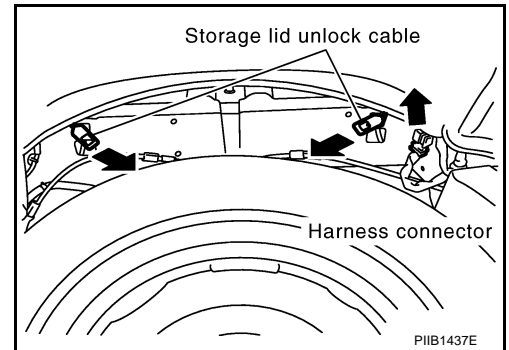

A

B

C

D

E

F

G

H

RF

J

K

L

M

STORAGE LID

PFP:97002

STORAGE LID

Removal and Installation of Storage Lid Assembly

AIS0065H

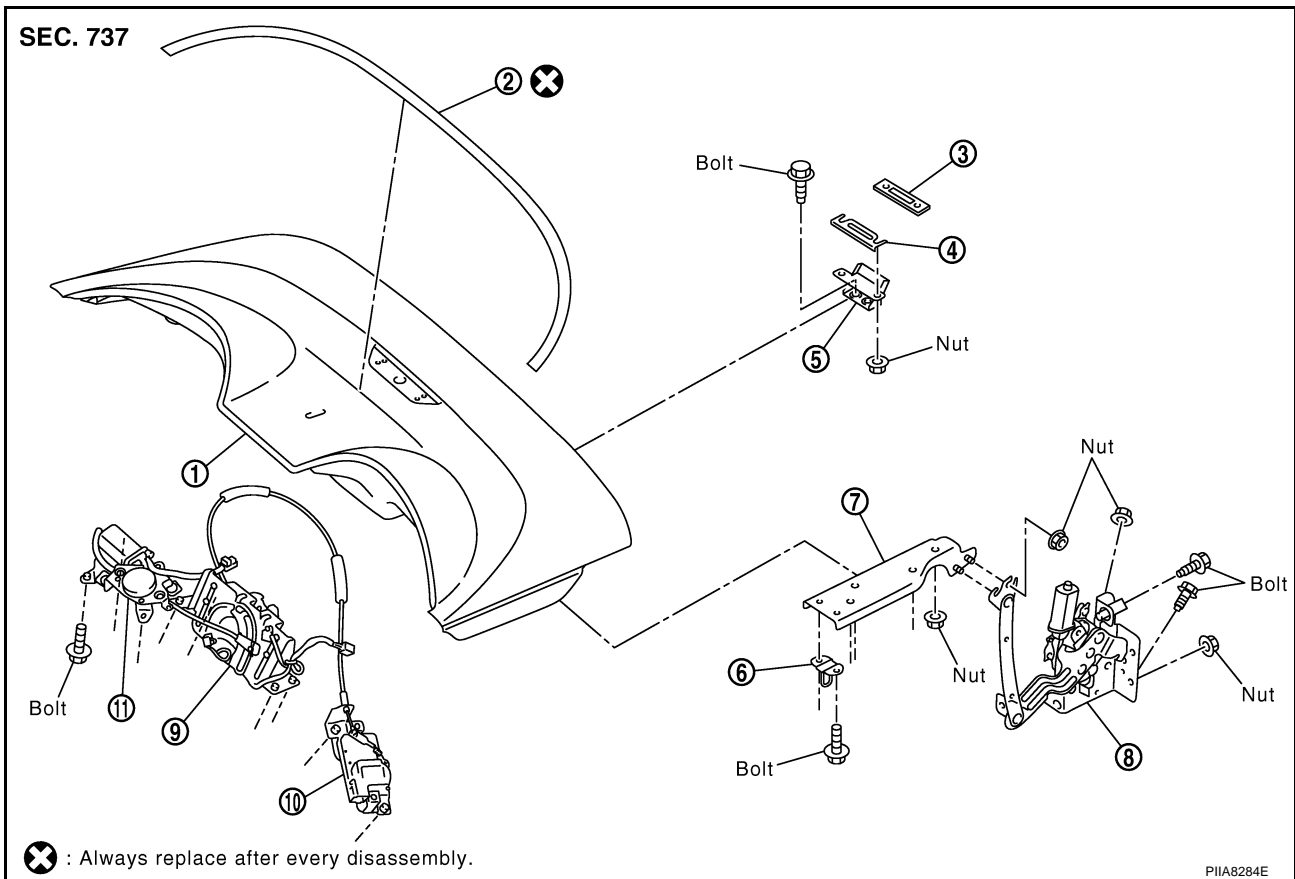

- | | | |
|------------------------------|------------------------------|------------------------|
| 1. Storage lid | 2. Storage outer protector | 3. Spacer |
| 4. Shim | 5. Storage lid hinge | 6. Storage lid striker |
| 7. Storage lid upper bracket | 8. Storage lid lower bracket | 9. 5th bow lock |
| 10. 5th bow unlock actuator | 11. 5th bow closure motor | |

REMOVAL

1. Disconnect storage lid actuator connector.
2. Remove bolts, and then remove storage lid striker.

NOTE:

- 2 or more workers are required.
- Paint matching marks to check location for installation.

3. Remove nuts which is connecting the storage lid upper bracket and the storage lid lower bracket.

NOTE:

Paint matching marks to check location for installation

4. Remove nuts of storage lid hinge, and then remove storage lid, spacers and shims.

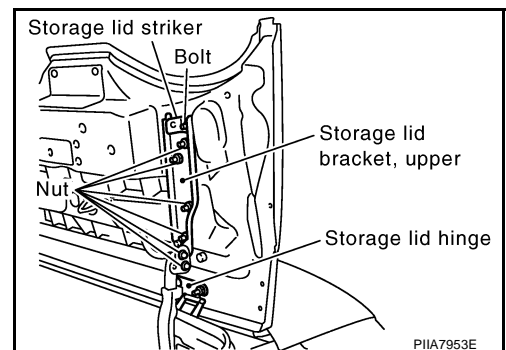

INSTALLATION

1. Install in the reverse order of removal.
2. Install storage lid, and then adjust fitting of lid.

STORAGE LID

Removal and Installation of Storage Lid Inside Unit

AI500651

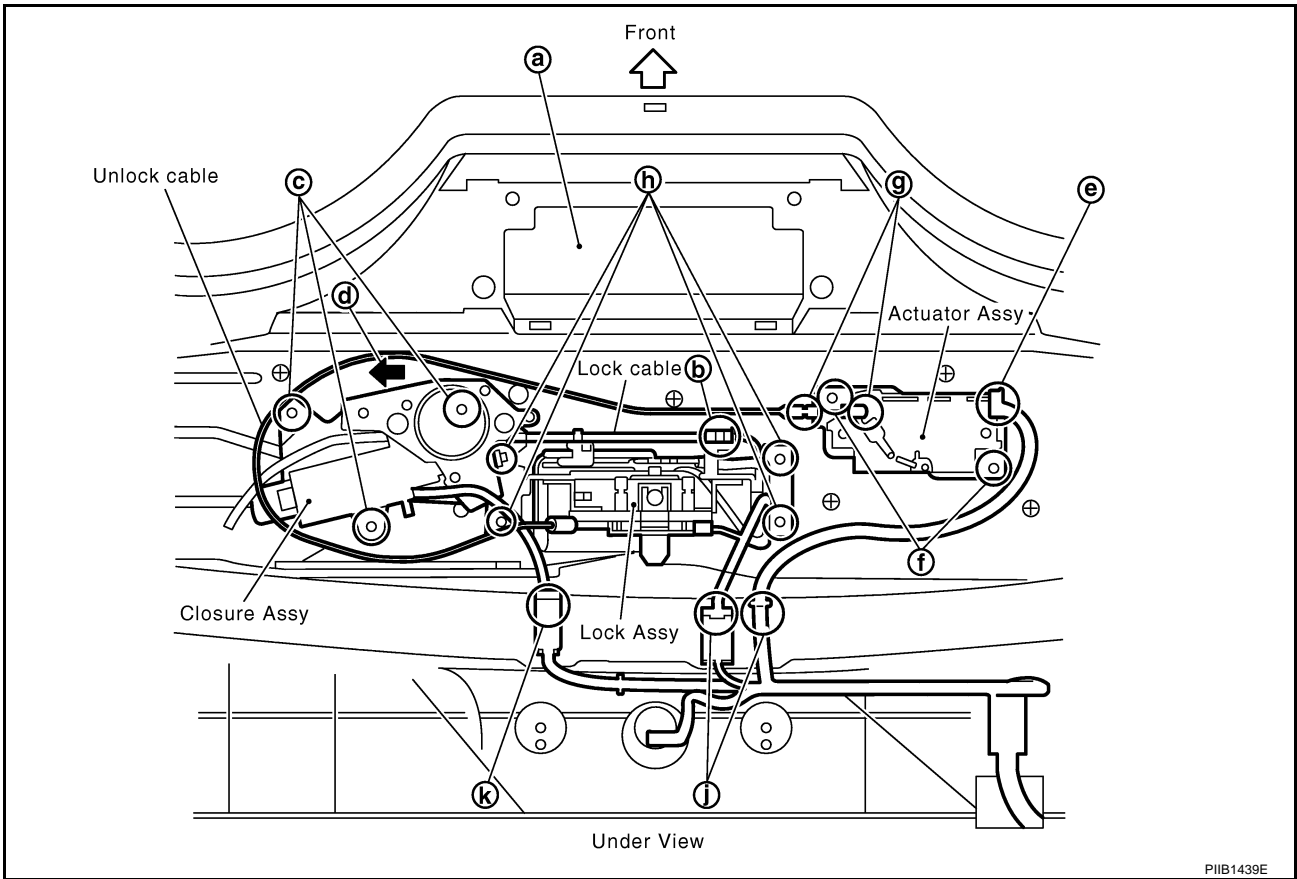

A
B
C
D
E
F
G
H

RF

REMOVAL

NOTE:

After installing Storage lid on the vehicle, an adjustment of Storage lid position is required in both closed and opened condition.

Put the removed storage lid on the floor or a work bench covered by waste clothes to prevent any scratches.

1. Remove storage lid inspection cover on the front side of Storage lid. (a in the figure)
2. Disconnect a wire from a lock assembly by pulling out a connection pin. (b in the figure)

NOTE:

The pin should be taken off by a small pliers not to fall into Storage lid. If the pin fell into Storage lid, then it is very difficult to take the pin out from the lid. And if the pin is left inside the lid, it may make an uncomfortable noise.

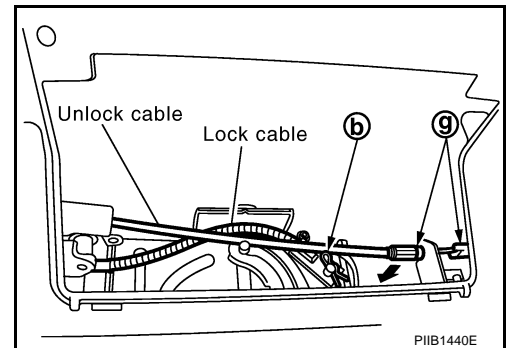

J
K
L
M

3. Remove closure mounting bolt from back of storage lid. (c in the figure)
4. Move closure toward outside of vehicle (because it interferes with unlock). (d in the figure)
5. Disconnect unlock actuator connector. (e in the figure)
6. Disconnect actuator side of unlock cable. (g in the figure)
7. Remove unlock actuator mounting bolt from back of storage lid, and then remove unlock actuator from inspection cover. (f in the figure)
8. Remove lock mounting bolt from back of storage lid, and then move entire lock toward rear of storage lid. (h in the figure)

STORAGE LID

9. Disconnect lock harness connector, and then remove lock from inspection cover. (j in the figure)

NOTE:

Turn lock catcher counterclockwise, and then face it to storage lid inspection hole side to remove because it interferes with storage lid when removing.

10. Disconnect closure harness connector, and then remove closure from inspection cover. (k in the figure)
11. Disconnect unlock actuator, lock, and closure harness connectors from inspection cover.
(Push in harness connector clip tabs from back of storage lid using a screwdriver so as to remove.)

INSTALLATION

Install in the reverse order of removal.

STORAGE LID

Removal and Installation of Storage Lid Actuator

AIS0065J

REMOVAL

1. Remove trunk room trim.
2. Remove nuts and bolts, and then remove storage lid lower bracket.

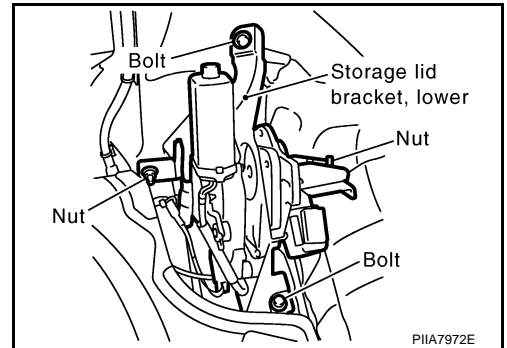

3. Disconnect storage lid actuator harness connector.
4. Remove nuts and remove storage lid actuator from storage lid bracket, lower.

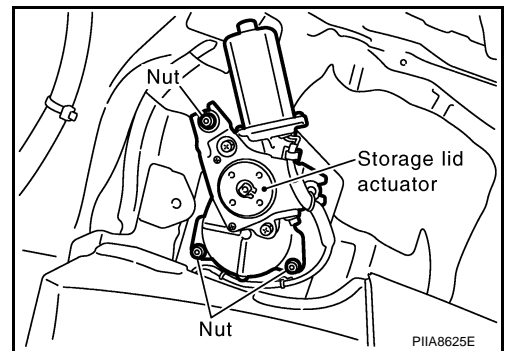

INSTALLATION

Install in the reverse order of removal.

Removal and Installation of Storage Room Finisher

AIS0065K

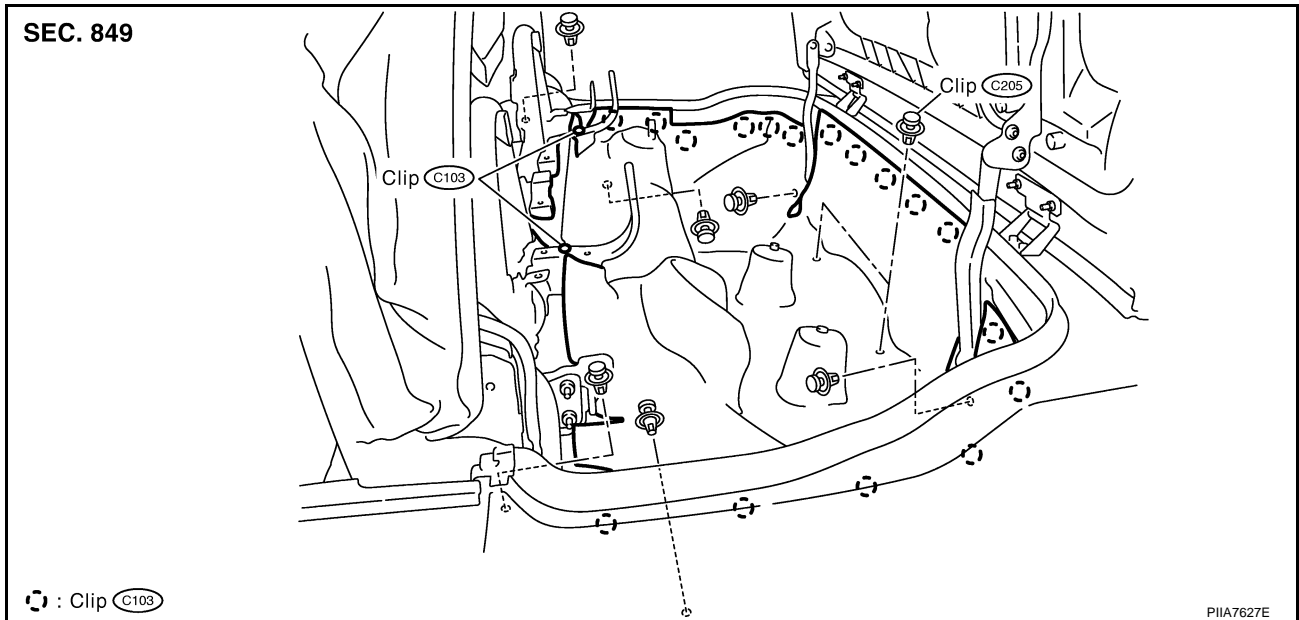

REMOVAL

1. Remove rear side finisher. Refer to [EI-29, "REAR SIDE FINISHER"](#).
2. Remove bolts, and then soft top mounting bracket (front).
3. Remove bolts, and then soft top mounting bracket (rear).
4. Lift up soft top mounting bracket using a lever, and then remove storage room finisher clips.
5. Remove storage room finisher clips, and then remove rear side of storage room finisher.

STORAGE LID

6. Lift up back panel finisher clips using remover tools, and then remove front side of storage room finisher.

INSTALLATION

Install in the reverse order of removal.

Removal and Installation of Storage Outer Protector

AIS0065L

Note the following, and install in the reverse order of removal.

1. Heat the bonded area using a hair dryer, and then remove storage outer protector.

NOTE:

Do not reuse storage outer protector after removing.

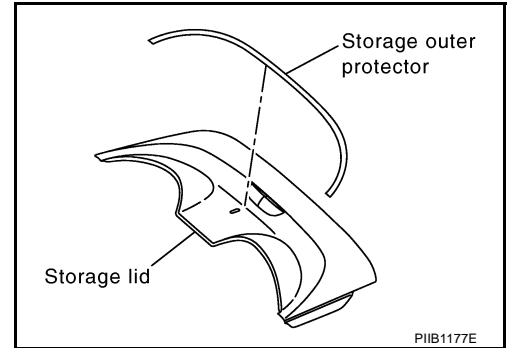

2. Remove storage room finisher.

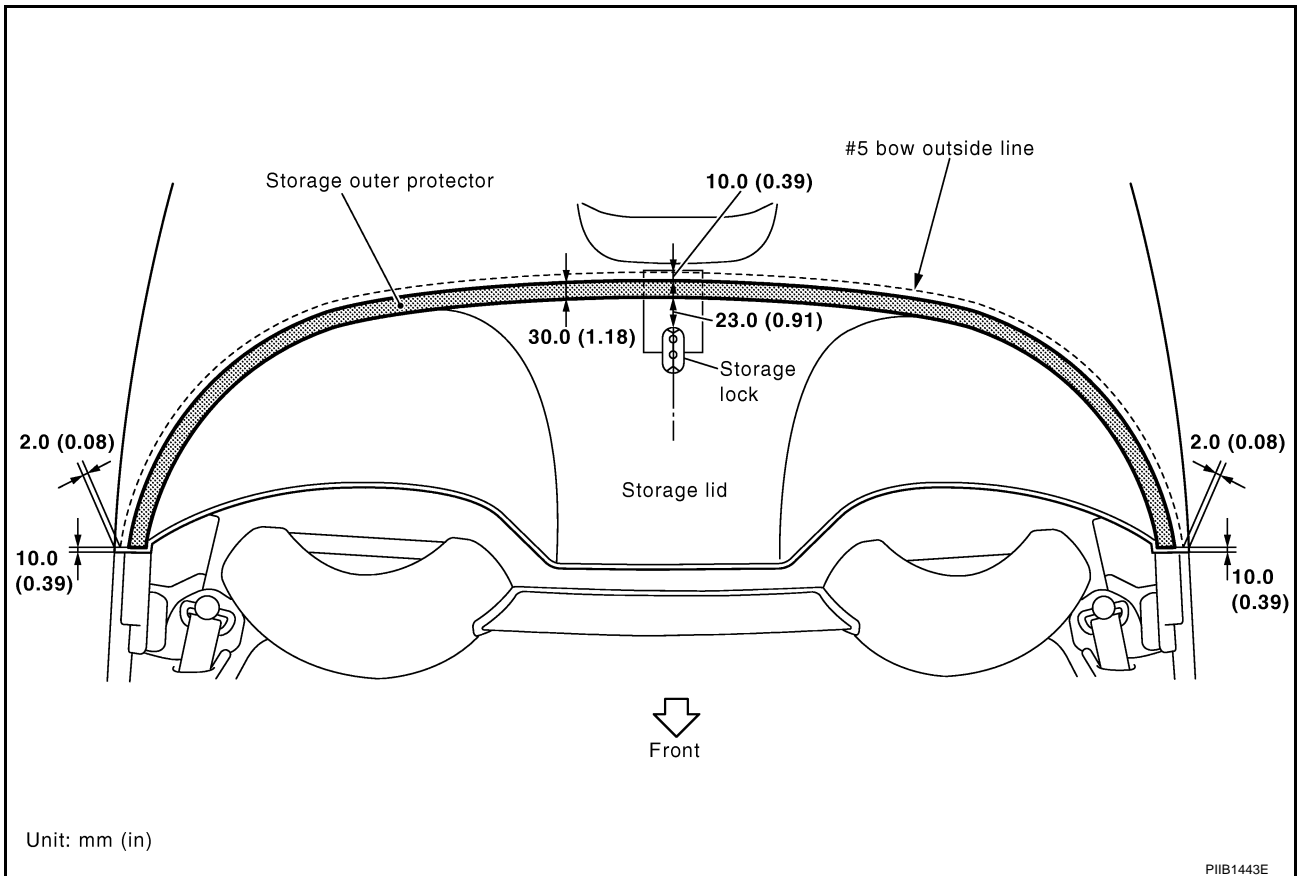

3. Clean Storage lid surface.
4. Close Soft top, and draw a line on a storage lid just behind the 5th bow out side edge by a water base marker pen.
5. Apply IPA solution (isopropyl alcohol : water = 1 : 1) on the lid, and set the storage outer protector position from one side. And do the same procedure to another side.
6. Apply left side storage lid outer aligning with left storage lid scribed line.
7. Apply right side storage lid outer aligning with right storage lid scribed line.

NOTE:

Not to put air or dust under the tape.

After applying the tape on the lid, peel off the protection film on the storage outer protector.

STORAGE LID

- Secure left, right, and front end of storage room finisher with remaining part when removing using double-faced adhesive tape.

Adjustment of Storage Lid ADJUSTMENT IN FULLY CLOSED POSITION

AIS0065M

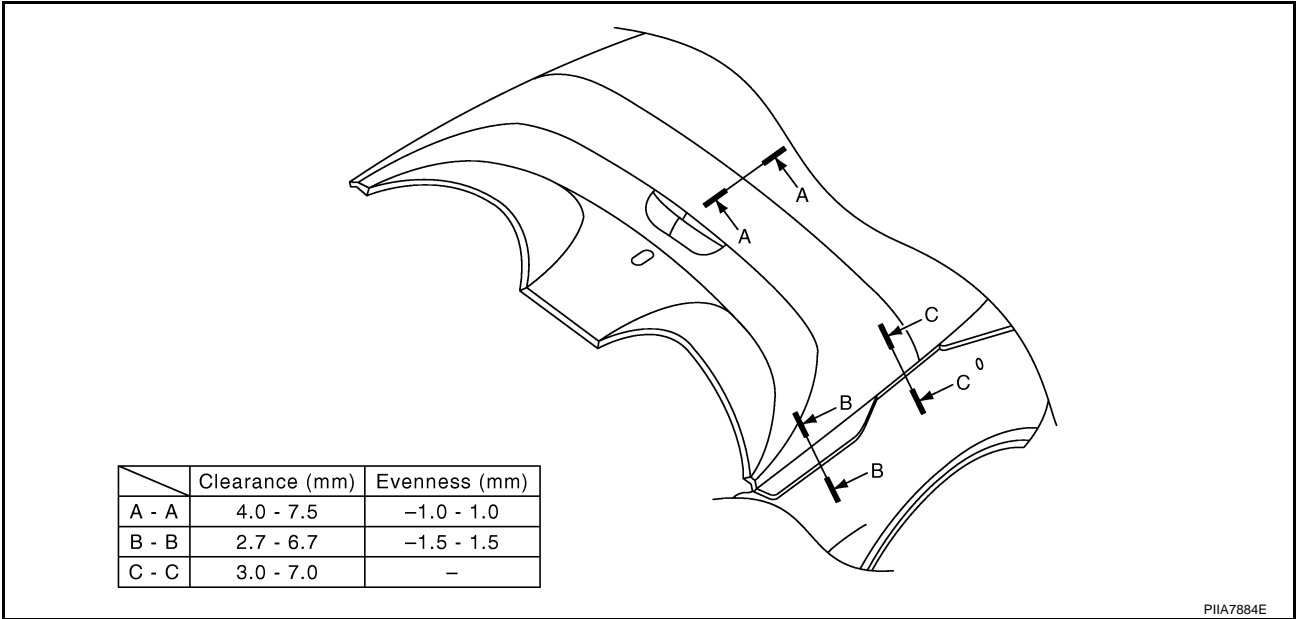

A-A Clearance Adjustment

Loosen nuts of storage lid hinge. Adjust storage lid until the clearance is within the specification.

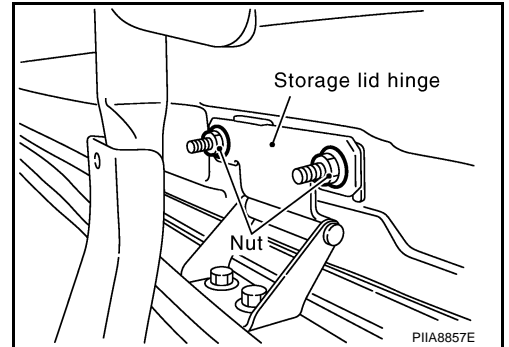

B-B Clearance Adjustment

Loosen nut of storage lid striker lock, and adjust it until the clearance is within the specification.

C-C Clearance Adjustment, A-A Evenness Adjustment

Loosen nuts of storage lid hinge. Adjust storage lid height by exchanging or adding shim until the evenness is within the specification.

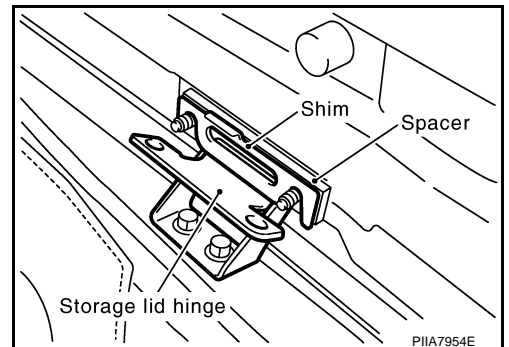

STORAGE LID

B-B Evenness Adjustment

Loosen nuts of storage lid hinge. Adjust the lid until the evenness is within the specification.

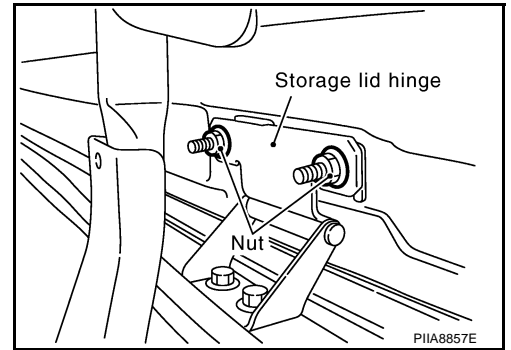

ADJUSTMENT IN FULLY OPENED POSITION

Adjust linkage position of storage lid striker and storage lid striker lock to specified dimension, by loosening nuts fixing storage lid bracket, upper and lower.

	Dimension (mm)
D - D'	566.0

PIIA8848E

STORAGE LID

Removal and Installation of Storage Lid Striker Lock & Storage Lid Emergency Opener Cable

AIS0065N

A
B
C
D
E
F
G
H
RF
J
K
L
M

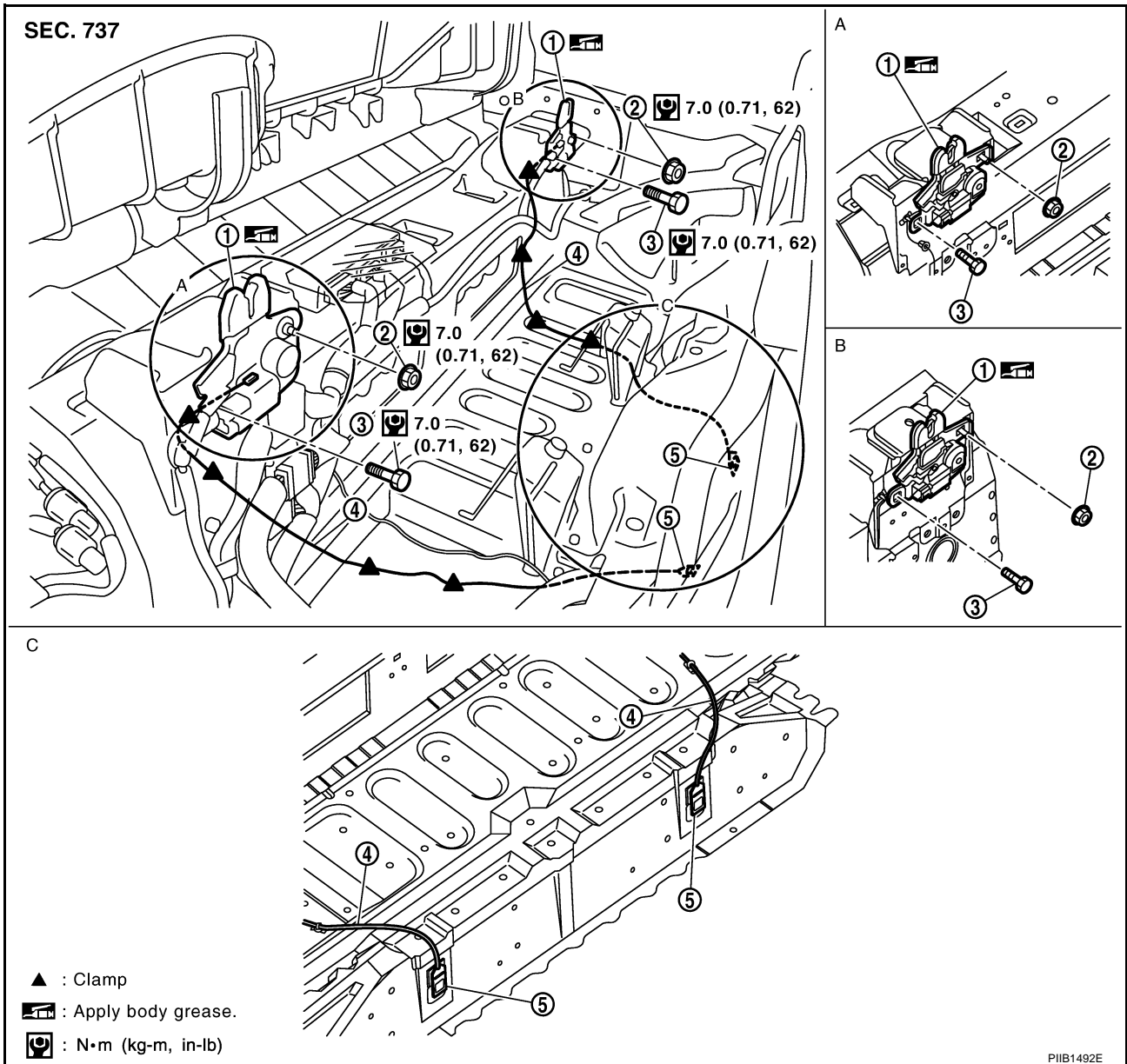

1. Storage lid striker lock assembly
2. Nut
3. Bolt
4. Storage lid emergency opener cable
5. Storage lid emergency opener hook

REMOVAL

1. Remove storage room finisher. Refer to [RF-125, "Removal and Installation of Storage Room Finisher"](#).
2. Remove trunk front finisher. Refer to [EI-35, "TRUNK ROOM TRIM & TRUNK LID FINISHER"](#).
3. Disconnect each clamp of storage lid emergency opener cable.
4. Disconnect each harness connector of storage lid lock assembly.
5. Remove storage lid lock mounting bolts, and then remove storage lid lock assembly.

INSTALLATION

Install in the reverse order of removal.

STORAGE LID
