

TOWER BAR

TOWER BAR

PF5:544A2

Removal and Installation

AES000DE

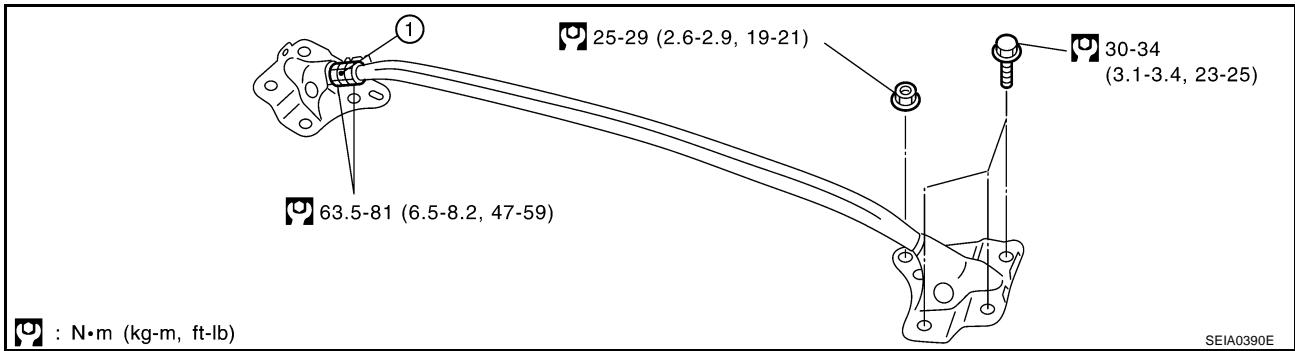

1. Center bolt

REMOVAL

1. Fix center bolt, and then loosen nut in the right and left side.
2. Loosen center bolt to the direction in the figure on 660° (Or turn bolt 1.7 times) to place the black mark of center bolt above.
3. Remove tower bar fixing bolts and nuts, and remove tower bar from vehicle with power tool.

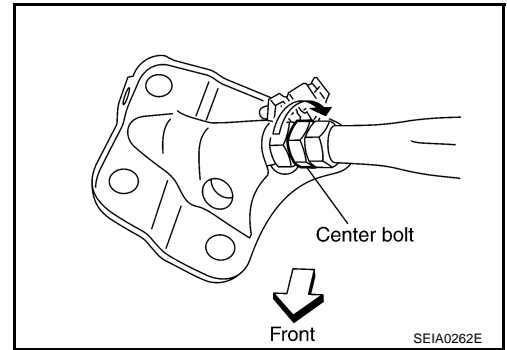

INSTALLATION

1. Install tower bar and tighten at the specified torque.

NOTE:

If it is hard to install tower bar, install it turning center bolt.

2. Tighten center bolt to the direction in the figure on 660° (Or turn bolt 1.7 times) to place the black mark of center bolt above.

NOTE:

The space between tower bar and engine collector should be between 10.0 mm (0.394 in) and 17.0 mm (0.669 in).

3. Tighten both nut of the right and left side of center bolt.

