

For the new harnesses with 3 connectors:

2 position connector: Aux Rev Limiter

Aux Rev Limiter - when enabled, these two wires need to be connected. To activate the auxiliary rev limiter, break the connection.

Colors: Blue, Purple

The auxiliary rev limiter trigger is on B12, and needs to rest in the grounded position if the aux limiter is enabled. When this ground is lifted from the ecu, the aux limiter will be activated.

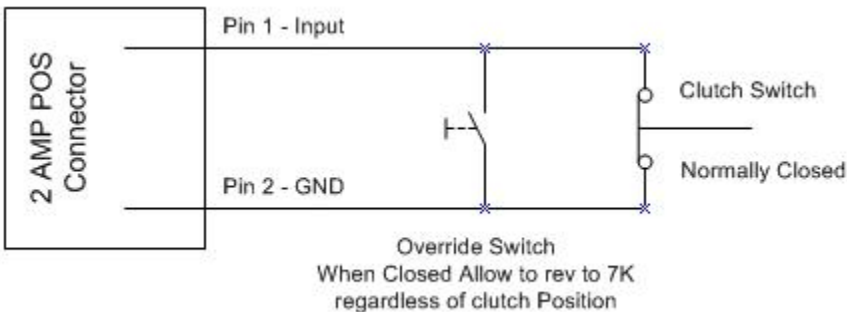

3 position connector: Boost Control Solenoid

Boost Control Solenoid wires are found on pins 1 & 2. These can be connected to the boost control solenoid in either order, with no concern for polarity.

Colors: Blue/Red, Black

Pin 3 is programmable output - The configurable output grounds the Haltech ECU pin C3. The pin will go to ground when active, and is low load and should only be used to trigger a relay. On newer harnesses (not sure which you have) that have 3 breakout connectors, you can use pin 3 on the 3pin connector.

4 position connector: External Map Sensor

The **Haltech** Platinum comes with an internal map sensor that reads up to 22psi of boost. For higher boost, an external map sensor can be connected here.

Pin 1 - sensor ground

Pin 2 - map sensor signal

Pin 3 - power, 5v

Pin 4 - nothing

Widebands - Aftermarket

Originally Posted by **sa@lol**

** *AFR Sensor:*

*To use an external wideband with the **Haltech**.*

*1. Cut the existing wire and terminate the wire side that is not attached to the **Haltech**. Attach the wire from the wideband analog out, to the remaining wire running to the **Haltech** as follows:*

*Wideband #1 ---> **Haltech Pin C7***

*Wideband #2 ---> **Haltech Pin C9***

*2. Calibrate the **Haltech** software the same as the wideband analog out.*

One other thing to note: if you will only be using 1 wideband, wire it into both #1 and #2. This is required for o2 feedback to work, as it reads and corrects specific to the wideband for each side. So, here are some modified instructions:

To use 1 aftermarket wideband:

1. Cut wires C7 and C9 coming from **Haltech** ECU. Attach the aftermarket wideband analog out wire to the remaining wires going into the **Haltech** ECU C7 + C9.
2. Calibrate the new sensors under Calibrations: Lambda Sensor 1 and 2

To use 2 aftermarket widebands:

1. Cut wire C7 coming from **Haltech** ECU for wideband bank 1. Attach wideband bank 1 to the remaining wire going into the **Haltech** ECU C7.
2. Cut wire C9 coming from **Haltech** ECU for wideband bank 2. Attach wideband bank 2 to the remaining wire going into the **Haltech** ECU C9.
3. Calibrate the new sensors under Calibrations: Lambda Sensor 1 and 2

MAF Removal and separate AIT Sensor Integration

Regarding the air temp sensor, I have run them a couple ways ... straight to the Haltech, or through the factory MAF wires. I would suggest for ease of install and to keep the stock ecu somewhat happy that you use the factory MAF wiring. I suggest you check with the FSM specific to your car.

MAF Removal - Air Temp Sensor Install

The oem MAF contains the stock air temp sensor; removing the MAF requires the addition of an air temp sensor by making the following changes:

1. The new air temp sensor will have two wires that need to connect to the following oem wires:
MAF Connector position 5 (Y/G on '04 350z) (ECU pin 34) - IAT
MAF Connector position 6 (B/W on '04 350z) (ECU pin 67) - ground
2. Calibrate map for the new air temp sensor under Calibrations:Air Temp Sensor

